

Leighton Joint Venture

Leighton Joint Venture



c/o 39th Floor
Sun Hung Kai Centre
30 Harbour Road
Hong Kong

t: (852) 2823-1111
f: (852) 2529-8784
e: info@leightonasia.com

By Hand

18-FEB-2015

Our Ref: H2613-LJV-EN-LE-1014

The EIA Ordinance Register Office
Environmental Protection Department
27/F, Southorn Centre
130 Hennessy Road
Wan Chai, Hong Kong

Dear Sir,

Contract No. HY/2011/08

**Central – Wan Chai Bypass – Tunnel Buildings, Systems and Fittings, and Works
Associated with Tunnel Commissioning**

Air Quality Management Plan (East Ventilation Building and East Vent Shaft) (Rev. 00)

Pursuant to Condition 2.13 of the Environmental Permit no. FEP-11/364/2009/B, we submit herewith four hard copies and one electronic copy of the Air Quality Management Plan for East Ventilation Building and East Vent Shaft (Rev. 00) with ET's certification letter and IEC's verification letter for your information.

Should you have any query, please do not hesitate to contact our Mr. Malcolm Leung at 6323 9478, or malcolm.leung@leightonasia.com.

Yours faithfully
For and on behalf of
Leighton Joint Venture

Colman Wong
Project Director

CW / RP / CC / ML / PY

cc. AECOM - Mr. David Kwan, CRE (w/ a CD only)
LAM - Mr. Raymond Dai, ETL (w/ a CD only)
ENVIRON - Mr. David Yeung, IEC (w/ a CD only)



Lam Geotechnics Limited

Ground Investigation & Instrumentation Professionals

Ref : G1120/CS/L933/FEP-11/364/2009/B
Date : 17 February 2015

Leighton Joint Venture
39/F Sun Hung Kai Centre
30 Harbour Road
Wan Chai

Attn: Site Agent, Mr. Colman Wong

Dear Mr. Wong,

Contract No. HY/2011/08
Central-Wanchai Bypass – Tunnel Buildings, Systems and Fittings, and
Works Associated with Tunnel Commissioning

Air Quality Management Plan (East Ventilation Building and East Vent Shaft) Rev.0

Referring to the captioned submission dated 17 February 2015 received through email on 17 February 2015, we have reviewed your submitted details and hereby certified this submission in accordance with Condition 2.13 of FEP-11/364/2009/B.

Should you have any enquiry, please feel free to contact the undersigned at 2839 5666.

Yours faithfully,

Raymond Dai
Environmental Team Leader

C.C.

HyD	- Mr. Bond Chow	(By Fax: 2714 5289)
AECOM	- Mr. Peter Poon	(By Fax: 3912 3090)
AECOM	- Mr. Frankie Fan	(By Fax: 2587 1877)
ENVIRON	- Mr. David Yeung	(By Fax: 3548 6988)



17 February 2015

Ref.: AACWBIECEM00_0_6258L.15

By Post and Fax (2140 6799)

Leighton Joint Venture
39th Floor
Sun Hung Kai Centre
30 Harbour Road
Hong Kong

Attention: Site Agent. Mr. Colman Wong

Dear Sir,

Re: Contract No. HY/2011/08
Central – Wan Chai Bypass – Tunnel Buildings, Systems and Fittings, and Works
Associated with Tunnel Commissioning
Air Quality Management Plan (East Ventilation Building and East Vent Shaft)
(Revision 0)

Reference is made to your submission of the Air Quality Management Plan (East Ventilation Building and East Vent Shaft) (Revision 0) dated 17 February 2015 to us through email on 17 February 2015 for our review and comment.

Please be informed that we have no further comments on the captioned submission. We write to verify the captioned submission in accordance with Condition 2.13 of FEP-11/364/2009/B.

Thank you for your kind attention.

Yours sincerely,

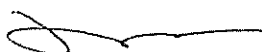

David Yeung
Independent Environmental Checker

c.c.	HyD	Mr. Bond Chow	by fax: 2714 5289
	AECOM	Mr. Peter Poon	by fax: 3912 3010
	LAM	Mr. Raymond Dai (ETL)	by fax: 2882 3331

Q:\Projects\AACWBIECEM00\Corr\AACWBIECEM00_0_6258L.15.doc

LEIGHTON
禮頓



**Contract No. HY/2011/08
Central – Wan Chai Bypass – Tunnel Buildings,
Systems and Fittings, and Works Associated with
Tunnel Commissioning**

**Air Quality Management Plan
(East Ventilation Building and East
Vent Shaft)**

Reviewed by:

Chris CHAN
Environmental Officer

Approved by:

Colman WONG
Site Agent

About this Document

This document is available for all project employees via the project network. We regularly revise this document and the latest version is always available electronically. Once printed, the document should no longer be considered to be the latest version. It may be distributed to the Highways Department and the Engineer on the understanding that any such document may not be the latest version or it may be distributed to the Highways Department and the Engineer as a controlled document in which case the front cover is to be stamped "Controlled Copy" in red and a copy number added.

The Environmental Officer is responsible for updating and maintaining the plan, including the original hard copy, which is signed by the person in charge of the project to indicate approval.

The status of this plan is identified by a revision number and date on each page. Changes to the document are identified by a vertical single line in the right-hand margin. On revision, the plan will be uploaded as a whole to the project server or within the Incite Keystone. The Environmental Officer maintains a record of the revision status of the plan, which is available on request.

If you have any enquiry relating to this plan, please contact the Environmental Officer.

Revision History and Plan Approval

Revision	Date	Section/Description	Prepared	Reviewed	Authorised by
00	17 Feb 2014	Issue for Construction	Penny YIU	Chris CHAN	Colman WONG

This plan is the property of Leighton Contractors (Asia) Limited and may not be copied, distributed or used without the written consent of Leighton Contractors (Asia) Limited.

Introduction

According to Special Condition 2.13 and Table 1b of the Further Environmental Permit (FEP) No. FEP-11/364/2009/B for this Contract No. HY/2011/08, this Air Quality Management Plan (AQMP) shows the layout plans, details and explanatory statements for the air mitigation measures to mitigate the potential air quality impact arising from the operation of the East Ventilation Building (EVB) and East Vent Shaft (EVS) under the Central-Wan Chai Bypass – Tunnel Buildings, Systems and Fittings, and Works Associated with Tunnel Commissioning Project (hereafter as “the Project”). The construction of the ventilation buildings and the vent shaft under the project shall follow the exhaust related design criteria based on Table 3.9 of the CWB&IECL EIA Report (AEIAR-041/2001) and Table 3.11 of the WDII&CWB EIA Report (AEIAR-125/2008). These criteria are also included in Table 1a and Table 1b of foregoing FEP. This submission is for EVB and EVS only as the building construction is scheduled to commence in near future and the AQMP for the Central Ventilation Building will be submitted separately.

Layout plans showing the site boundary of the Project with locations of West Ventilation Building, Central Ventilation Building, East Ventilation Building and East Vent Shaft are attached in Appendix A.

The scope of the Project mainly includes:

- Construction of the tunnel control buildings and ventilation buildings including Administration Building, West Ventilation Building, Central Ventilation Building, East Ventilation Building and East Vent Shaft;
- Associated road lighting, road signing, traffic control and surveillance system; and
- Other associated works.

1 Exhaust Related Design Criteria of the East Ventilation Building and East Vent Shaft

With reference to Table 1b of the above FEP-11/364/2009/B, the exhaust related design criteria of the Vent Shaft of the East Ventilation Building are listed in Table 1 below.

Table 1 Exhaust Related Design Criteria of Vent Shaft of the East Ventilation Building

	Cross-sectional Area of Stack (m ²)	Exit Velocity (m/s)	Minimum Mid-discharge Height (meter above ground)	Exhaust Direction
East Ventilation Building (EVB) - Vent shaft	94	8	16.25	Inclined 45 degree upward (discharge towards sea direction)

2 Air Quality Mitigation Measures

2.1 Vent Shaft of the East Ventilation Building

2.1.1 Cross-sectional area of stack and Exit Velocity

In accordance with the Particular Specification Section 36 – Tunnel Ventilation System Installation, Clause 36.12(3)(iv), six tunnel ventilation fans EVB-TVF004, EVB-TVF005, EVB-TVF006, EVB-TVF007, EVB-TVF008 and EVB-TVF009 with air flow duty of 125 m³/s will be responsible for tunnel ventilation, refer to the PS stated in Appendix B. Therefore, the maximum flow of the ventilation fans is 750m³/s (see note below). Refer to Appendix C1-3, the opening of exhausted discharge louvre at

the top of the East Vent Shaft with secondary structure and fins installed has an effective area 94 m², which has resulted an exit velocity of 8m/s.

2.1.2 Minimum Discharge Height and Discharge Direction

With reference to Appendix C1 and C4, the exhausted discharge louvre is inclined 45 degree upward and facing towards sea direction and the mid-level discharge of the East Vent Shaft is 16.25m higher than the minimum discharge height.

Note: The number of ventilation fans (TVF series) installed at the above ventilation buildings will be operated in parallel, however, the total number of fans operating will depend on air quality inside the tunnel. There shall be emergency backup mode of operation incorporated in the design.

2.2 “Zero Portal Emission Design” of East Tunnel Portal

Zero Portal Emission Design is achieved by operating the extraction fans for the eastern tunnel portal, refer to Appendix D for the overall Tunnel Ventilation System schematic. The extraction fans will be operated via tunnel Central Control and Monitoring System (CCMS) to control the air from tunnel section. Velocity sensors are installed at the exit portal to monitor the airflow direction of the tunnel, it triggers the operation of tunnel ventilation system when the tunnel air velocity towards portal is larger than 0m/s. The extracted air is released through overhead ventilation duct to vent shaft of East Ventilation Building.

3 Electrostatic Precipitator System (EPS)

An air purification system (APS), including an EPS with removal efficiency of at least 80% of dust to reduce the level of respirable suspended particulates (RSP), and a NO₂ removal system with removal efficiency of at least 80%, would be adopted to improve the air quality before discharging to the atmosphere via the EVS. The preliminary design of the system was submitted to the client's representative and approved on 1 September 2014. The approval document is attached in Appendix E. Also enclosed in this appendix is an extract from the approved submission stating that the APS design is made up of an ESP (Electrostatic Precipitation) filter for particle separation and a DeNO₂ filter for gas adsorption which could reduce the amount of particles and NO₂ in the tunnel airstream with separation efficiency greater than 80%. As an example, the FILTRONtec designed, supplied and installed a DeNO₂ filter as part of the Sydney M5 East AFP based on the activated carbon performance characteristics of 98% of NO₂ removal.

Detailed design stage is ongoing till the third quarter of year 2015 and the detailed design submission shall be made for client's approval in due course.

4 Job References

Job references for using the system in other countries are quoted as below:

Project	FILTRONtec ESP Modules Supplied (H x W x D)
Madrid M30 tunnel <ul style="list-style-type: none"> - PER 8, capacity 50m³/s, - PECE 2, capacity 260m³/s - CET-EXT 1, capacity 200m³/s 	21 x Type 934-101 (0.64 x 0.934 x 0.62 SS316L 160kg) 89 x Type 934-101 (0.64 x 0.934 x 0.62 SS316L 160kg) 77 x Type 934-101 (0.64 x 0.934 x 0.62 SS316L 160kg)

Project	FILTRONtec ESP Modules Supplied (H x W x D)
Sydney M5 East AFP tunnel <ul style="list-style-type: none"> - Capacity 200m³/s 	79 x Type 934-102 (0.64 x 0.934 x 0.62 SS316L 160kg)

Leighton JV

**Contract No. HY/2011/08
Central-Wan Chai Bypass – Tunnel Buildings, Systems and Fittings,
and Works Associated with Tunnel Commissioning
Air Quality Management Plan (East Ventilation Building and East Vent Shaft)**

Appendix A Site Layout Plans

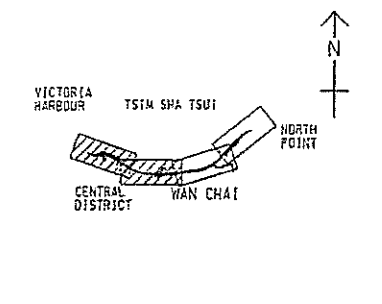
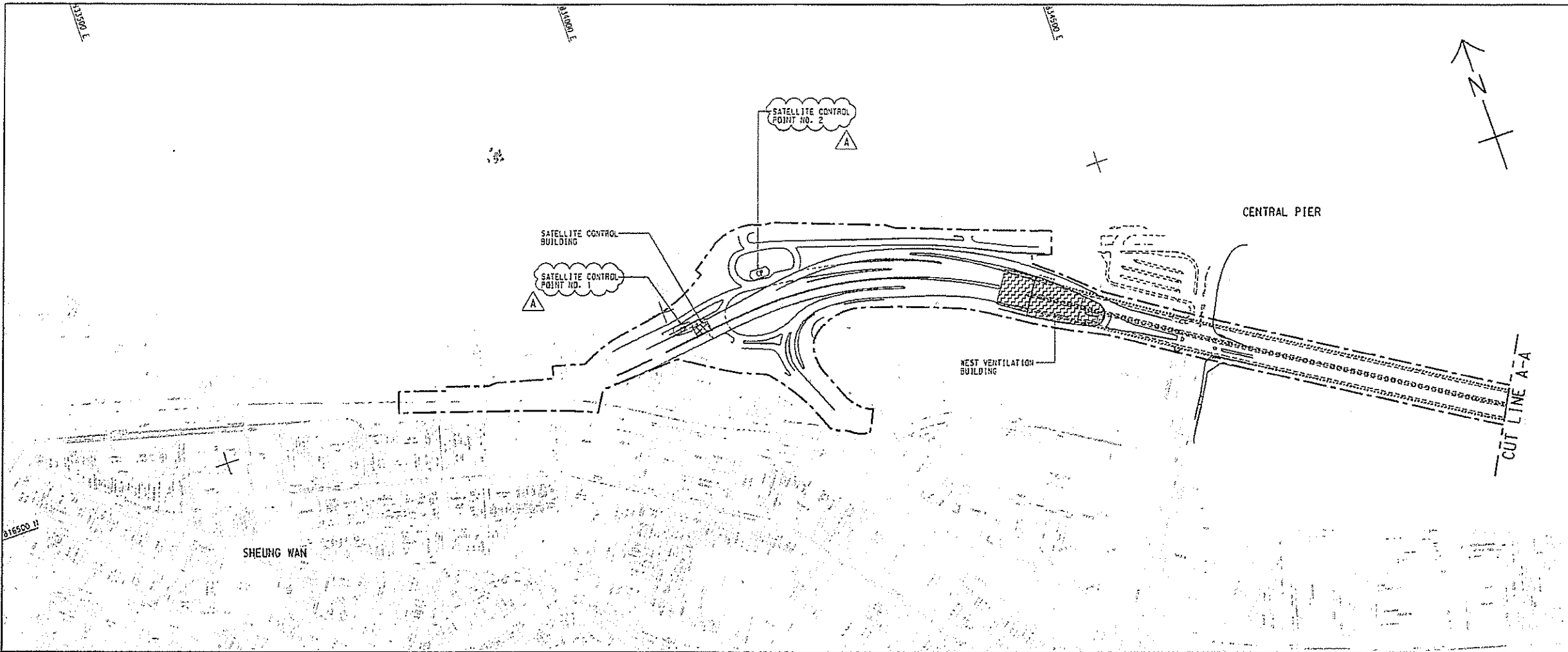

KEY PLAN
SCALE A1 : 100000
A3 : 200000

- NOTES:**
1. THIS DRAWING TO BE READ IN CONJUNCTION WITH DRAWING NO. 60095653/RW/1002.
 2. ALL DIMENSIONS ARE IN METRES UNLESS NOTED OTHERWISE.
 3. DETAILS INCLUDING DIMENSIONS, LEVELS, DESCRIPTIONS, LOCATIONS, ETC. GIVEN FOR EXISTING ROADS, FOOTPATHS, BRIDGE STRUCTURES ARE INDICATIVE ONLY. THE CONTRACTOR SHALL VERIFY THE ACTUAL EXISTING DETAILS ON SITE.

- LEGEND:**
- SITE BOUNDARY
 - CP CONTROL POINT
 - [Hatched Box] WEST VENTILATION BUILDING
 - [Cross-hatched Box] SATELLITE CONTROL BUILDING
 - [Dotted Box] MIDDLE VENTILATION BUILDING
 - [Star-patterned Box] EAST VENTILATION BUILDING
 - [Grid-patterned Box] ADMINISTRATION BUILDING
 - EAST VENT SHAFT

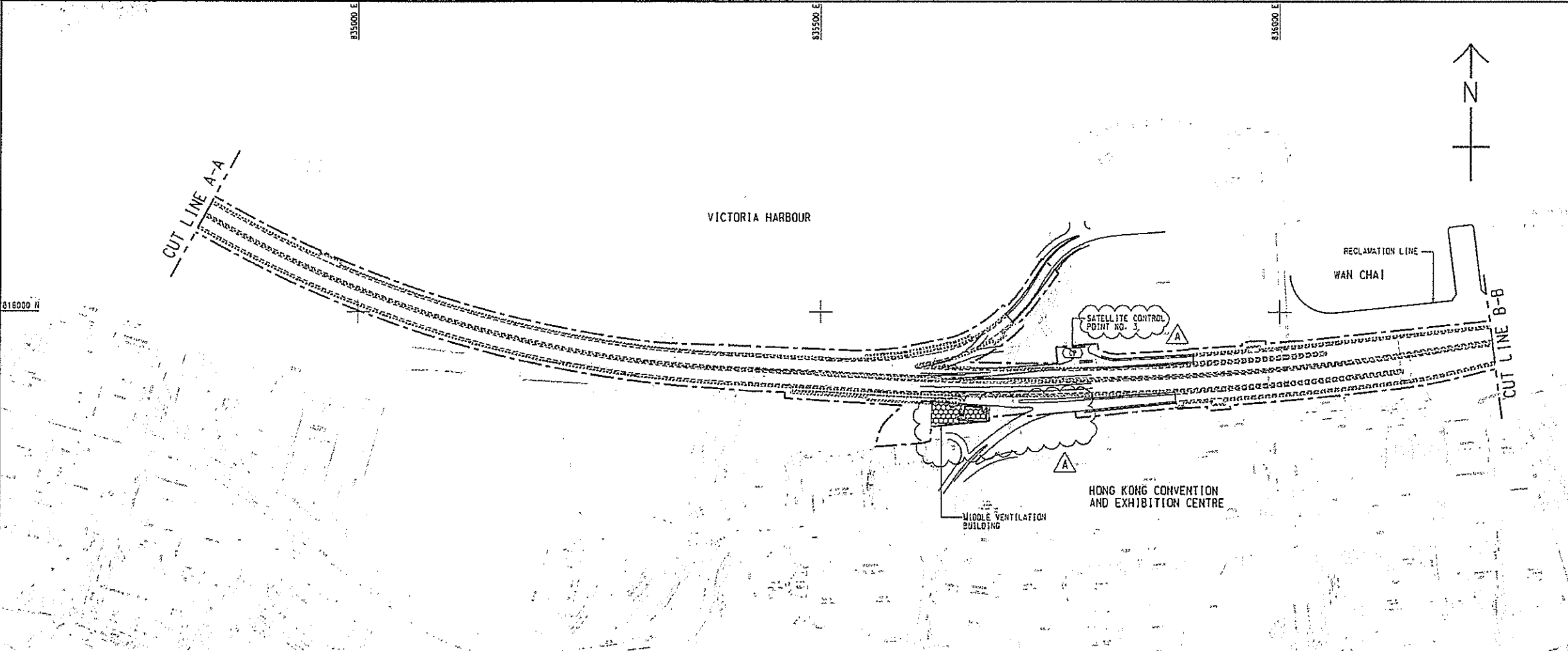

B	WORKING DRAWING	JWK/ALCF	MAR 14
A	TENDER ADDENDUM NO. 1	JWK/ALCF	JUN 13
-	TENDER DRAWING	JWK/ALCF	MAY 13
NO.	DESCRIPTION	DATE	SIGNATURE

Highways Department 路政署
Major Works Project Management Office

CENTRAL - WAN CHAI BYPASS AND IEC LINK

PWP ITEM NO. 579 TH
工務計劃項目編號

CENTRAL - WAN CHAI BYPASS - TUNNEL BUILDINGS, SYSTEMS AND FITTINGS, AND WORKS ASSOCIATED WITH TUNNEL COMMISSIONING

GENERAL LAYOUT
SHEET 1 OF 2



DRG. NO. 60095653/RW/1001B
圖紙編號

DESIGNED BY ALCF	CONTRACT NO. HY/2011/08	A. E. APPROVED CHK
DRAWN BY LHJ	SCALE A1 : 2500 A3 : 5000	DATE 2011/04/27
WORKING DRAWING		
© COPYRIGHT RESERVED 版權所有		

2011-4-27
 P:\Projects\60095653\Drawing\CC1000RW_1001.dwg

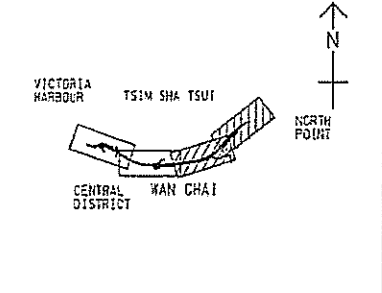
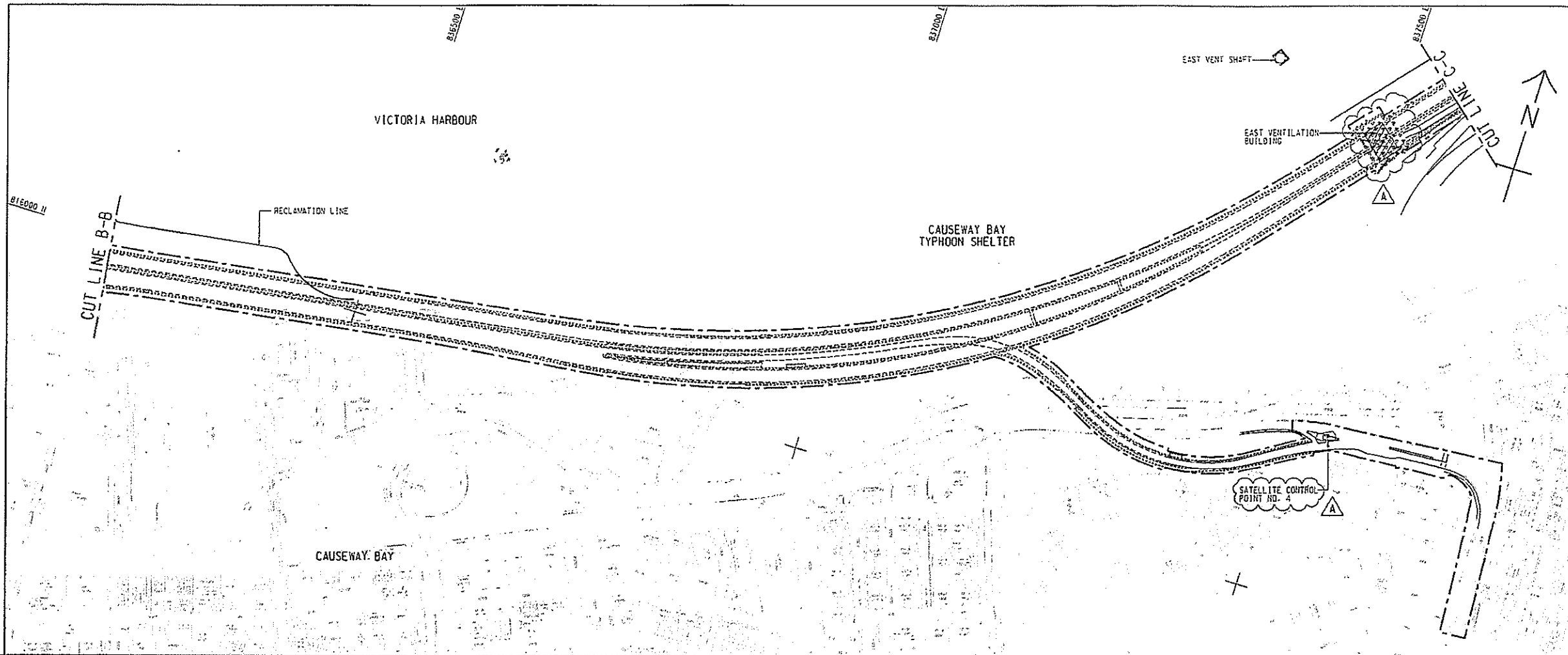

KEY PLAN
SCALE A1 : 100000
A3 : 200000

- NOTES:**
1. THIS DRAWING SHALL BE READ IN CONJUNCTION WITH DRAWING NOS. 60095653/RW/1001.
 2. FOR NOTES AND LEGEND REFER TO DRAWING NO. 60095653/RW/1001.

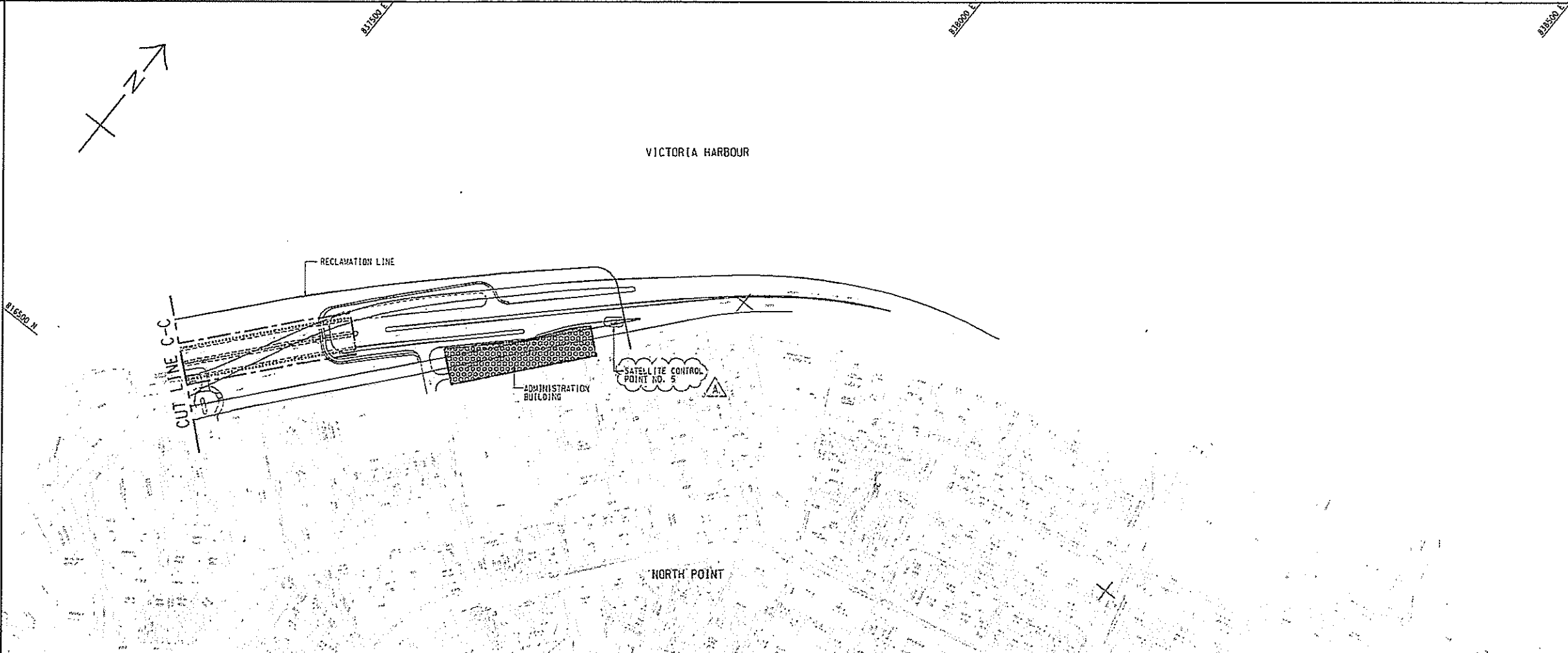

REV	NO	DESCRIPTION	DATE
B	WORKING DRAWING	JWK/ALCF	MAR 14
A	TENDER ADDENDUM NO. 1	JWK/ALCF	JUN 13
-	TENDER DRAWING	JWK/ALCF	MAY 13

Highways Department 路政署
Major Works Project Management Office

CENTRAL - WAN CHAI BYPASS AND IEO LINK

PWP ITEM NO. 579 TH
工務計劃項目編號

CENTRAL - WAN CHAI BYPASS -
TUNNEL BUILDINGS, SYSTEMS AND FITTINGS,
AND WORKS ASSOCIATED WITH TUNNEL COMMISSIONING

GENERAL LAYOUT

SHEET 2 OF 2



DRGNO. 60095653/RW/1002B
圖號

DESIGNED BY: ALCF
CHECKED BY: HY/2011/08
APPROVED BY: CMY

SCALE A1 1 : 5000
A3 1 : 10000
WORKING DRAWING

© COPYRIGHT RESERVED
版權所有

Leighton JV

**Contract No. HY/2011/08
Central-Wan Chai Bypass – Tunnel Buildings, Systems and Fittings,
and Works Associated with Tunnel Commissioning
Air Quality Management Plan (East Ventilation Building and East Vent Shaft)**

Appendix B Particular Specification – Tunnel Ventilation System Fan

(iv) Performance

(a) The duty performance requirements for the tunnel ventilation fans are specified in the following table:

Vent Bldg TVFs (Type)	Forward Duty with APS	Forward Duty without APS	Reverse Duty without APS	Remarks
WVB-TVF 001-003 (NEF)	Nil	80m ³ /s @1800Pa TP	80m ³ /s @1800Pa TP	250°C 1hr 100% reversible
WVB-TVF 004-005 (ANF)	125m ³ /s @2800Pa TP	Nil	Nil	
MVB-TVF 001-006 (NEF)	Nil	80m ³ /s @1800Pa TP	80m ³ /s @1800Pa TP	250°C 1hr 100% reversible
MVB-TVF 007-008 (ANF)	125m ³ /s @2300Pa TP	125m ³ /s Note (1)	Nil	
MVB-TVF 009-010 (ANF)	125m ³ /s @3300Pa TP	125m ³ /s Note (1)	Nil	
MVB-TVF 011(ANF)	125m ³ /s @2400Pa TP	Nil	Nil	
MVB-TVF 012-013 (ANF)	125m ³ /s @3300Pa TP	Nil	Nil	
EVB-TVF 001-003 (NEF)	Nil	80m ³ /s @1700Pa TP	80m ³ /s @1700Pa TP	250°C 1hr 100% reversible
EVB-TVF 004-006 (AEF)	125m ³ /s @4800Pa TP	125m ³ /s Note (1)	125m ³ /s Note (1)	250°C 1hr less than 100% reversible
EVB-TVF 007-009 (AEF)	125m ³ /s @4800Pa TP	125m ³ /s Note (1)	Nil	250°C 1hr

Notes:

- The Contractor shall calculate the total pressure of the fan system during forward mode without APS and / or during reverse mode without APS.
- All duty points are based on standard temperature and pressure conditions. Pressures specified are total pressures (TP) corresponding to the fan diameters as per the Drawings.
- The flow rate listed in the above table is minimum requirement.

(b) All TVFs shall be operable within a range from 0°C to 50°C and 95%RH in a tunnel environment. In addition, the whole AEFs and NEFs assembly, including fan, fan motor, etc., shall not suffer mechanical, electrical or structural failure when operating at full capacity in an ambient air temperature of 250°C for a minimum period of 1 hour.

(c) All TVF associated ductwork shall be able to withstand a maximum pressure of ±6kPa.

(d) Reversible impellers shall be used, if applicable. The fan flow performance in both forward and reverse directions shall be at least 100% as per Clause 36.12(3)(iv).

(e) The protection rating shall be IP55 for TVF motors and all

Leighton JV

**Contract No. HY/2011/08
Central-Wan Chai Bypass – Tunnel Buildings, Systems and Fittings,
and Works Associated with Tunnel Commissioning
Air Quality Management Plan (East Ventilation Building and East Vent Shaft)**

Appendix C1- 4 Working drawings of EVS

Appendix C 1

Mid Discharge Height (m)
21.45 - 5.20
= 16.25m

Cross-sectional area of stack (m²)
Area of cone surface = 129.14m²

Effective area of louvre = 94m²

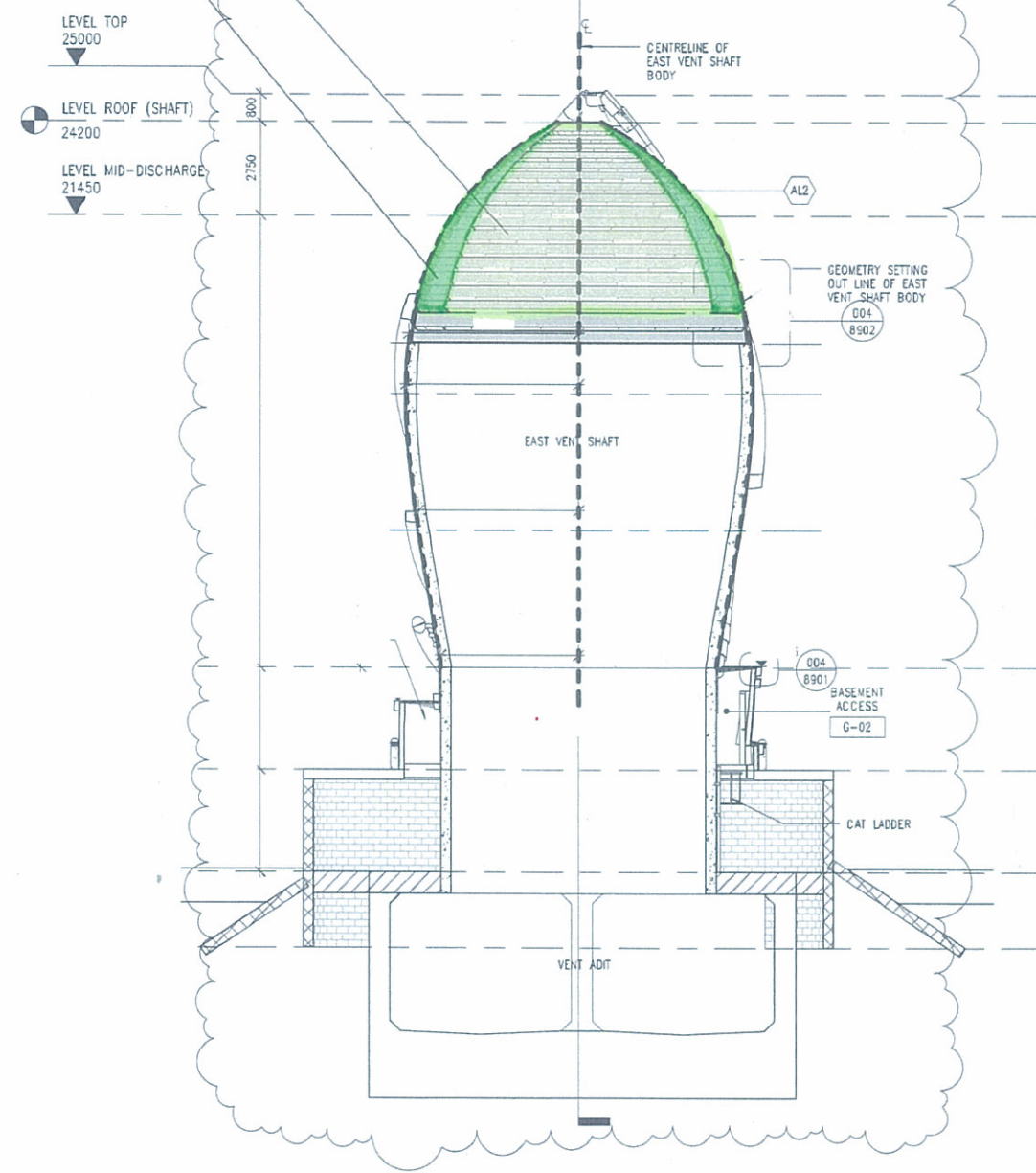
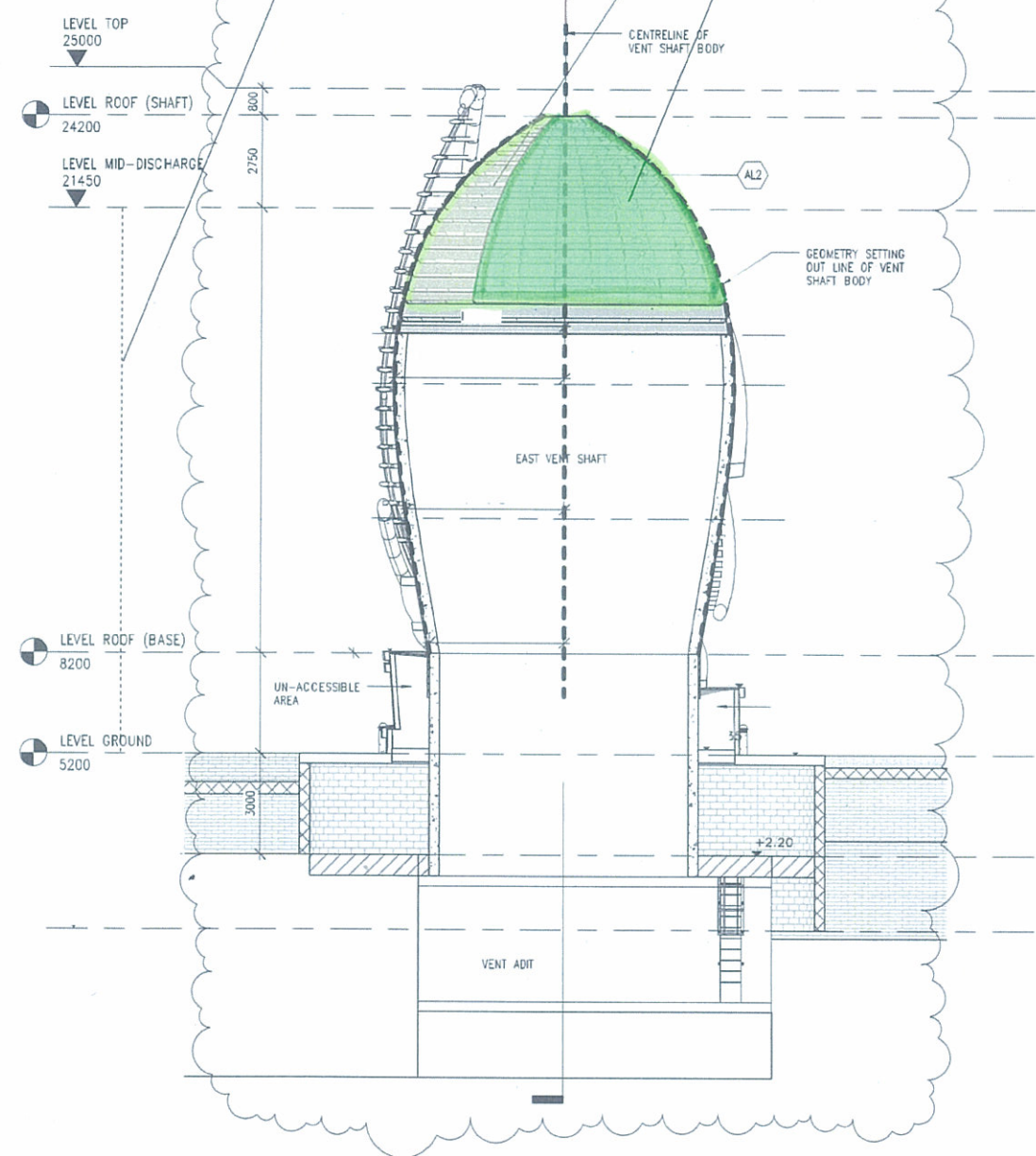

NOTES:
1. FIXING DETAILS OF ALL ARCHITECTURAL FEATURE OF EVS SHALL BE DESIGNED BY THE CONTRACTOR. SHOP DRAWING SHALL BE SUBMITTED TO THE ENGINEER FOR COMMENT AND APPROVAL PRIOR TO COMMENCEMENT OF WORKS.

B	WORKING DRAWING	CHW	ALCF	MAR 14
A	TENDER ADDENDUM NO.1	CHW	ALCF	JUN 13
-	TENDER DRAWING	CHW	ALCF	MAY 13
REV	DESCRIPTION	DATE	BY	CHK

Highways Department 路政署
Major Works Project Management Office

CENTRAL - WAN CHAI BYPASS AND IEC LINK

PWP ITEM NO. 579 TH
工務計劃項目編號

CENTRAL - WAN CHAI BYPASS -
TUNNEL BUILDINGS, SYSTEMS AND FITTINGS,
AND WORKS ASSOCIATED WITH TUNNEL COMMISSIONING
EAST VENT SHAFT
CROSS SECTIONS

AECOM

DRG NO. 60095653/RW/7971 B
圖紙編號

DESIGNED BY CHW CONTRACT NO. HY2011/08
DRAWN BY ERL STATUS WORKING DRAWING
SCALE AS SHOWN GA1

DIMENSIONS ARE IN MILLIMETERS
COPYRIGHT RESERVED
版權所有

P:\09015\CAD\REVIT\CENTRAL FILE\60095653_04_EVIS_ARCH.rvt 0/17/2013 3:58:00 PM

001 SECTION A-A

SCALE 1 : 100

002 SECTION B-B

SCALE 1 : 100

Appendix C2

Mid Discharge Height (m)
21.45 - 5.20
= 16.25m

Cross-sectional area of stack (m²)
Area of cone surface = 129.14m²

Effective area of louvre = 94m²

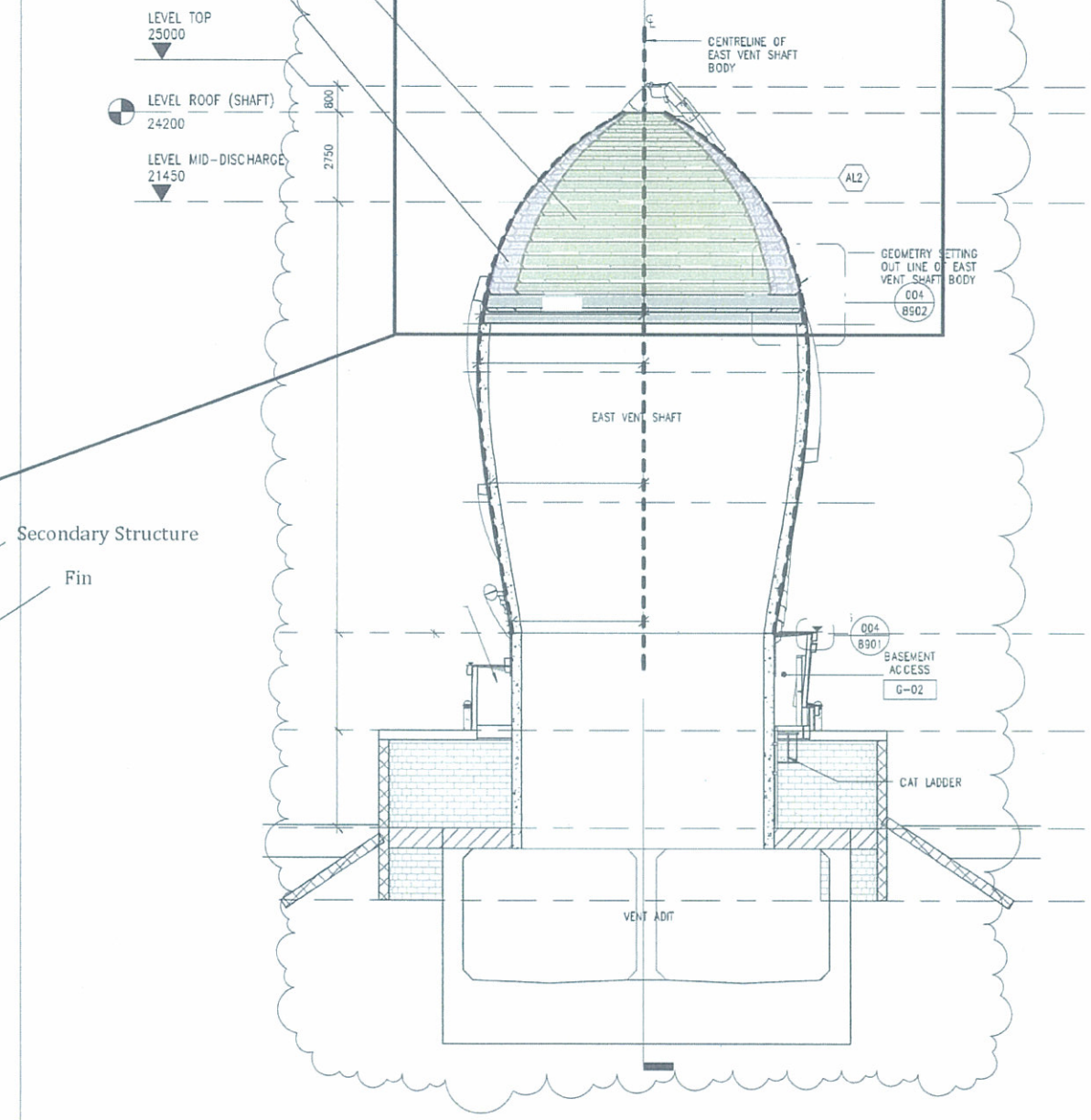
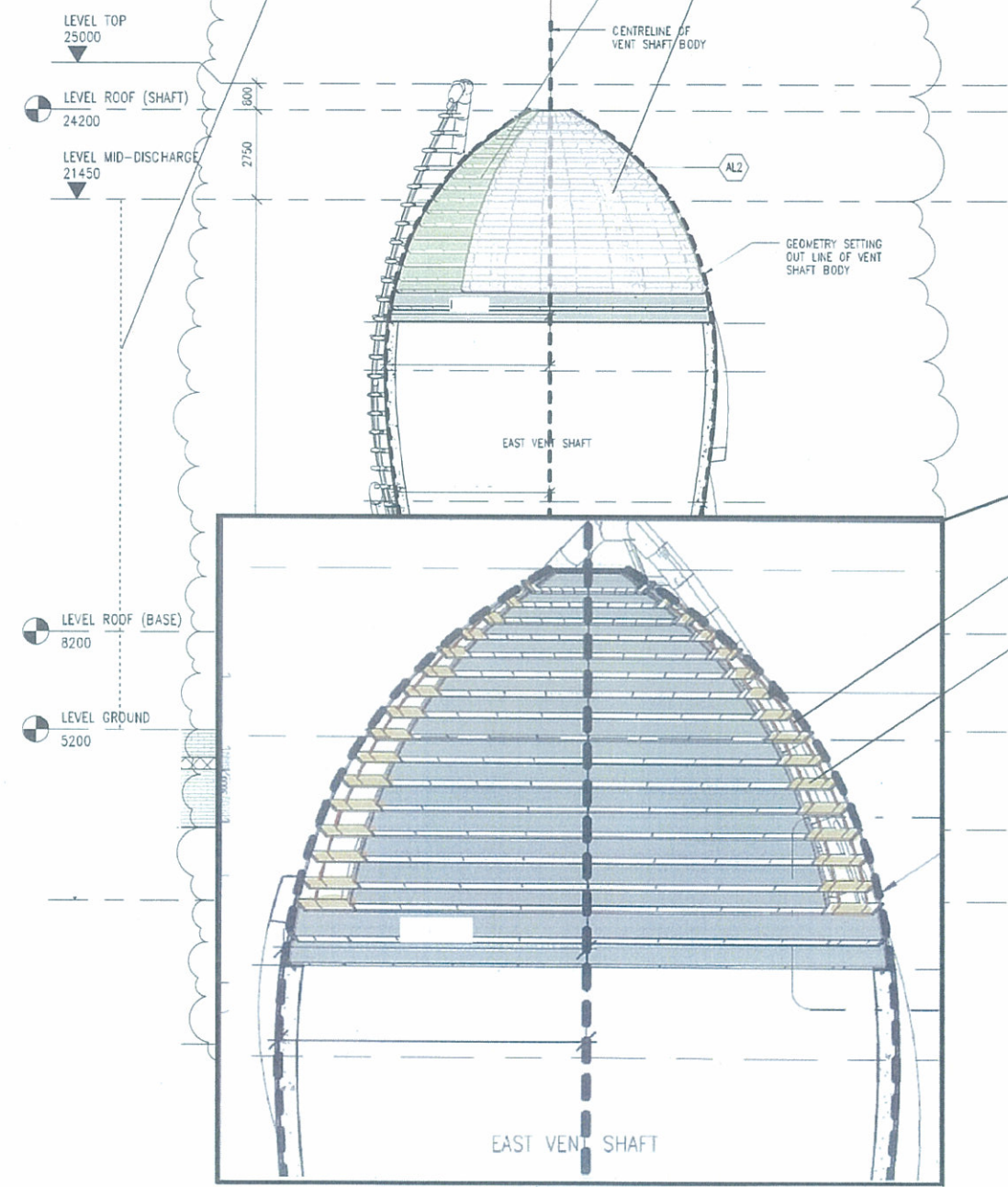

NOTES
1. FIXING DETAILS OF ALL ARCHITECTURAL FEATURE OF EVS SHALL BE DESIGNED BY THE CONTRACTOR. SHOP DRAWING SHALL BE SUBMITTED TO THE ENGINEER FOR COMMENT AND APPROVAL PRIOR TO COMMENCEMENT OF WORKS

B	WORKING DRAWING	CHW	ALCF	MAR 14
A	TENDER ADDENDUM NO.1	CHW	ALCF	JUN 13
-	TENDER DRAWING	CHW	ALCF	MAY 13
REV	DESCRIPTION	DATE	BY	DATE

Highways Department 路政署
Major Works Project Management Office

CENTRAL - WAN CHAI BYPASS AND IEC LINK

PWP ITEM NO. 579 TH
工務計劃項目編號

CENTRAL - WAN CHAI BYPASS -
TUNNEL BUILDINGS, SYSTEMS AND FITTINGS,
AND WORKS ASSOCIATED WITH TUNNEL COMMISSIONING
EAST VENT SHAFT
CROSS SECTIONS

AECOM

DRG NO. 60095653/RW/7971 B
圖紙編號

DESIGNED BY CHW CONTRACT NO. HY2011/08 AP'D & APPROVED BY CHW

DRAWN BY ERL STATUS 1:1 WORKING DRAWING

SCALE 1:1 AS SHOWN @A1
DIMENSIONS IN MILLIMETERS © COPYRIGHT RESERVED 版權所有

P:\0018\CADD\REVIT\CENTRAL FILE\60095653_04_LEVS_ARCH\14 6/17/2013 3:58:00 PM

001 SECTION A-A

SCALE 1 : 100 002 SECTION B-B

SCALE 1 : 100

Appendix C3

Mid Discharge Height (m)
21.45 - 5.20
= 16.25m

Cross-sectional area of stack (m²)
Area of cone surface = 129.14m²

Effective area of louvre = 94m²

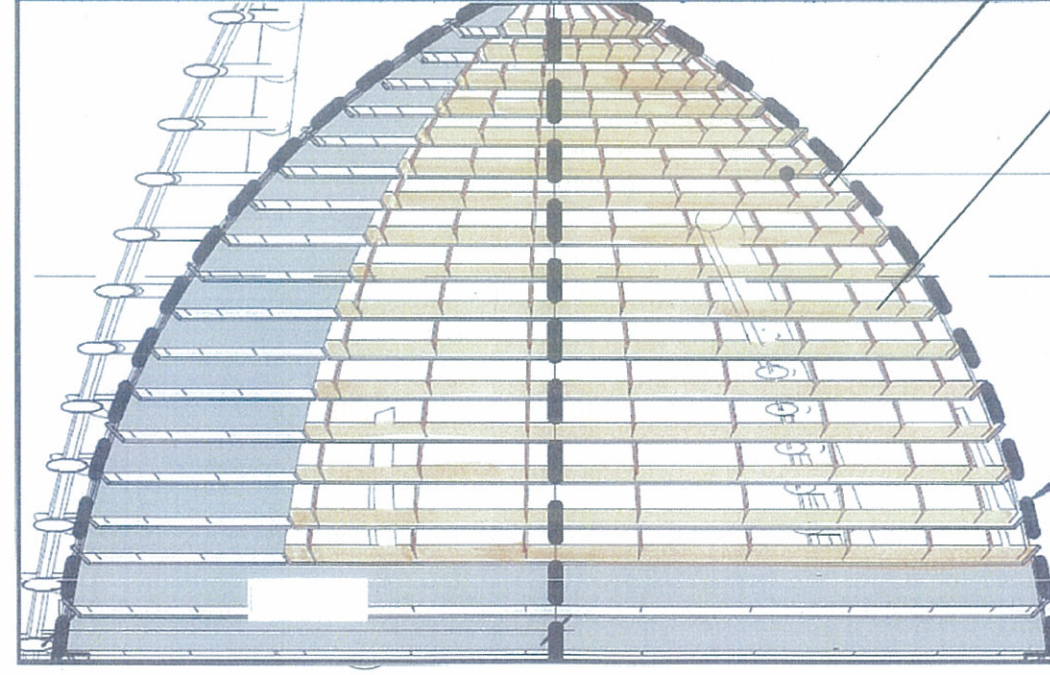
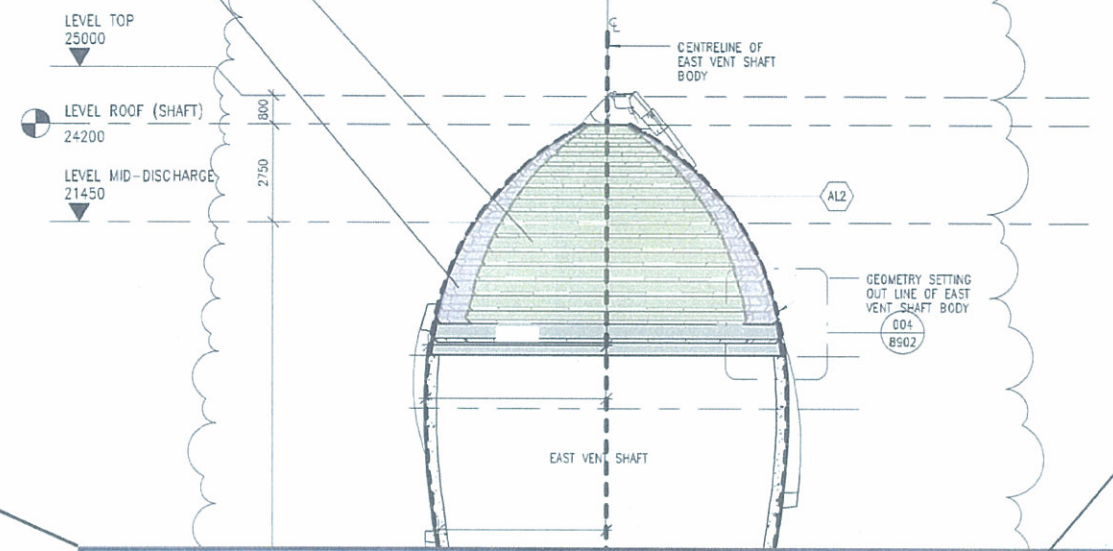
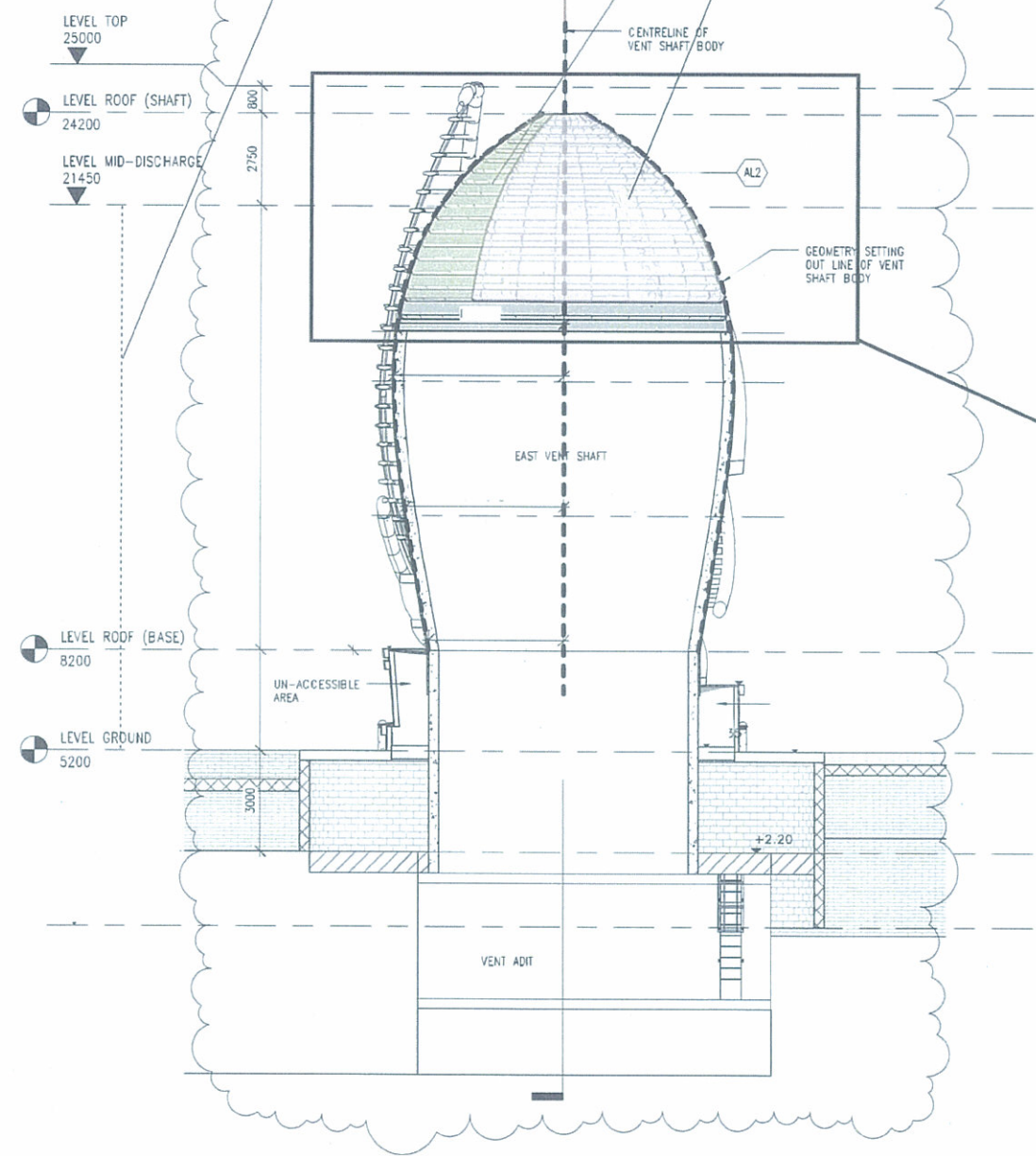

NOTES
FIXING DETAILS OF ALL ARCHITECTURAL FEATURE OF EVS SHALL BE DESIGNED BY THE CONTRACTOR. SHOP DRAWING SHALL BE SUBMITTED TO THE ENGINEER FOR COMMENT AND APPROVAL PRIOR TO COMMENCEMENT OF WORKS

B	WORKING DRAWING	CHW	ALCF	MAR 14
A	TENDER ADDENDUM NO.1	CHW	ALCF	JUN 13
-	TENDER DRAWING	CHW	ALCF	MAY 13
REV	DESCRIPTION	DATE	BY	CHKD

Highways Department 路政署
Major Works Project Management Office

CENTRAL - WAN CHAI BYPASS AND IEC LINK

PWP ITEM NO. 579 TH
工務計劃項目編號

CENTRAL - WAN CHAI BYPASS -
TUNNEL BUILDINGS, SYSTEMS AND FITTINGS,
AND WORKS ASSOCIATED WITH TUNNEL COMMISSIONING
EAST VENT SHAFT
CROSS SECTIONS

AECOM

DRG NO 60095653/RW/7971 B
圖號編號

DESIGNED BY CHW CONTRACT NO. HY2011/08 AP'D BY APPROVED
DRAWN BY ERL STATUS: WORKING DRAWING

SCALE: AS SHOWN @A1
DIMENSIONS ARE IN MILLIMETERS
© COPYRIGHT RESERVED
版權所有

P:\05015CADD\REVIT\CENTRAL FILE\60095653_04_EVS_ARCH.rvt 01/17/2013 3:58:00 PM

001 SECTION A-A

SCALE 1 : 100

002 SECTION B-B

SCALE 1 : 100

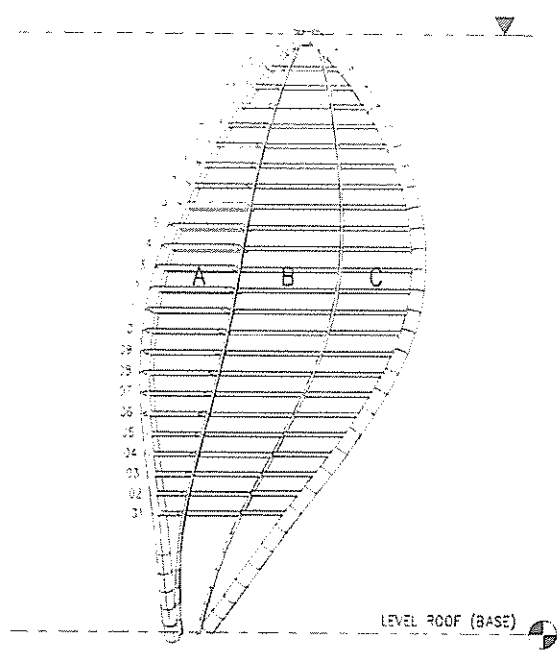

001 MAJOR FIN MEMBER NO. KEY

SCALE 1:100

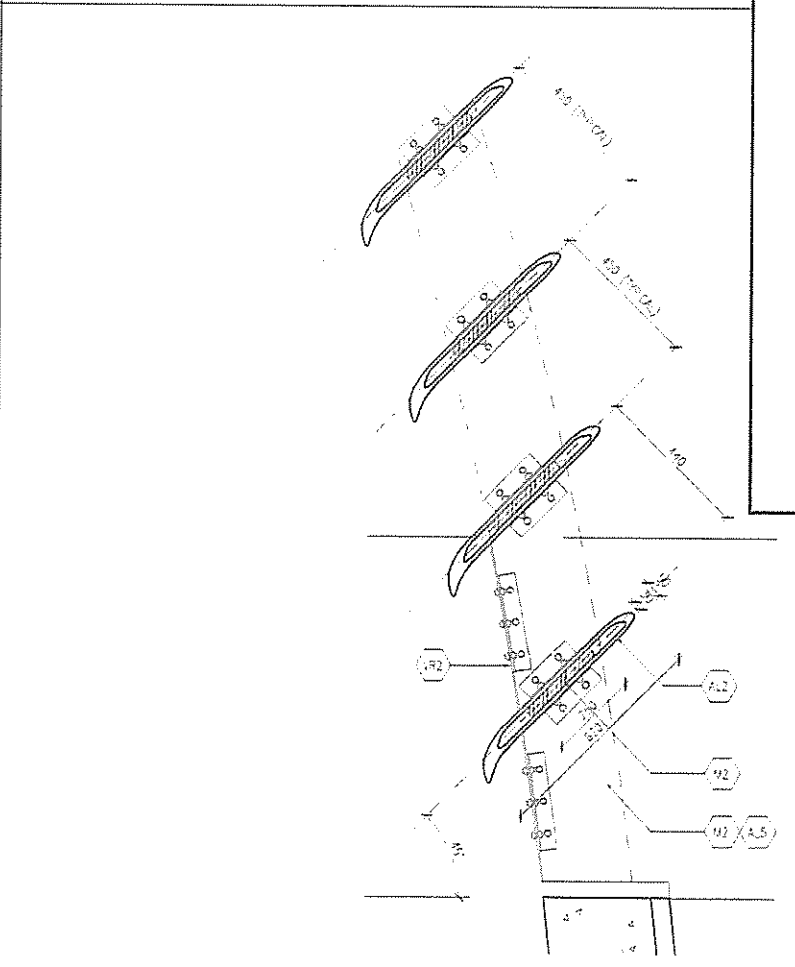
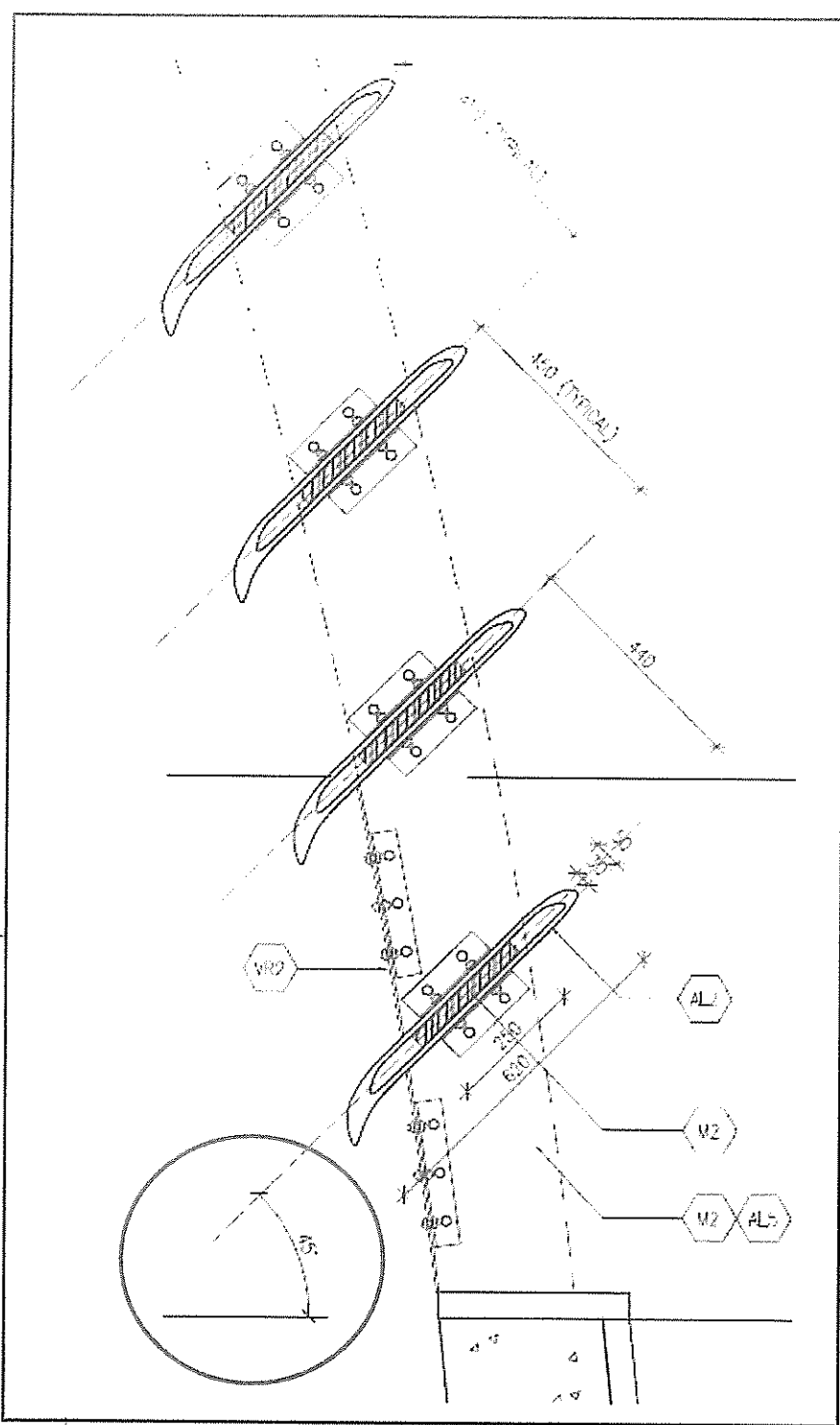

004 TYPICAL SECTION - TOP VENT DISCHARGE

SCALE 1:10

NOTE:

Appendix C4

B	WORKING DRAWING	CHN/ALCP/MAR 14
A	TENDER APPENDUM NO 2	CHN/ALCP/JUL 13
-	TENDER DRAWING	CHN/ALCP/MAY 13

Highways Department 路政署
Major Works Project Management Office

CENTRAL - WAN CHAI BYPASS AND IEG LINK

PWP ITEM NO. 579 TH
工程計劃項目編號

CENTRAL - WAN CHAI BYPASS -
TUNNEL BUILDINGS, SYSTEMS AND FITTINGS,
AND WORKS ASSOCIATED WITH TUNNEL COMMISSIONING

EAST VENT SHAFT DETAILS

SHEET 2 OF 2

AECOM

DRG. NO. 60095653/RW/8902 B
圖紙編號

DESIGNED BY S-W	CHECKED BY S-W	DATE 14/03/14
DRAWN BY EPL	SCALE AS SHOWN	PROJECT NO. 60095653
WORKING DRAWING		
COPYRIGHT RESERVED 版權保留		

Leighton JV

Contract No. HY/2011/08
Central-Wan Chai Bypass – Tunnel Buildings, Systems and Fittings,
and Works Associated with Tunnel Commissioning
Air Quality Management Plan (East Ventilation Building and East Vent Shaft)

Appendix D Tunnel Ventilation System Overall TVS Schematic

- NOTES:**
- FOR LEGEND, GENERAL NOTES AND ABBREVIATIONS, REFER TO DRAWING NO. 60095653/RW/4100
 - THE TUN-SIL-001 TO 004 WILL BE INSTALLED IN FRONT AND BEHIND THE TUN-TJF-001 AND TUN-TJF-002 RESPECTIVELY.

EAST VENTILATION BUILDING (EVB)
(REFER TO DRG NO. 60095653/RW/4124 FOR DETAILED TVS SCHEMATIC IN EVB)

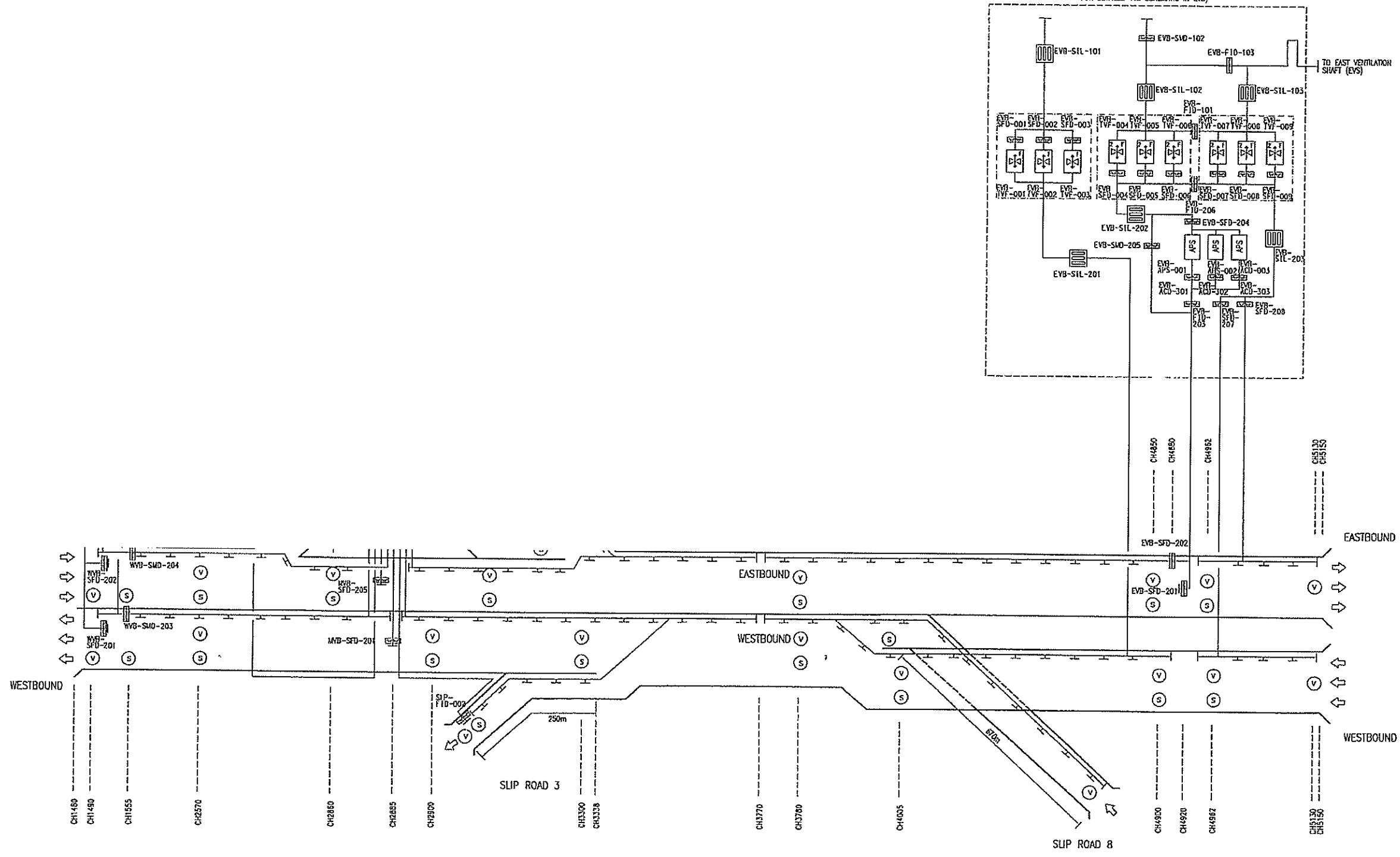
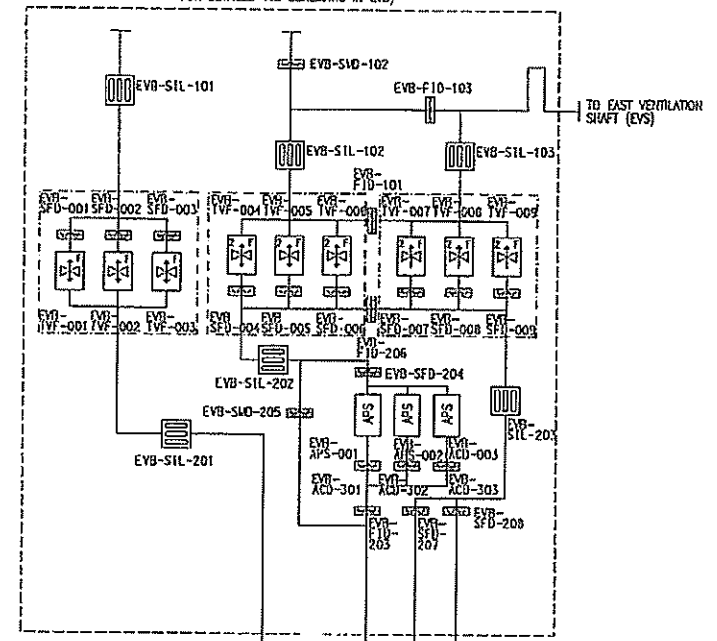

A	WORKING DRAWING	2011/05	MAR 14
-	TENDER DRAWING	2011/05	MAY 13
BY	DESIGNED	2011/05	MAY 13
BY	CHECKED	2011/05	MAY 13
BY	APPROVED	2011/05	MAY 13

Highways Department 路政署
Major Works Project Management Office

CENTRAL - WAN CHAI BYPASS AND IEC LINK

PWP ITEM NO. 579 TH
工務計劃項目編號

CENTRAL - WAN CHAI BYPASS -
TUNNEL BUILDINGS, SYSTEMS AND FITTINGS,
AND WORKS ASSOCIATED WITH TUNNEL COMMISSIONING
**TUNNEL VENTILATION SYSTEM
OVERALL TVS SCHEMATIC**



DRG. NO. 60095653/RW/4121A
圖號編號

DESIGNED BY XZH	CHECKED BY HY/2011/06	APPROVED BY CRJ
DRAWN BY DXT	SCALE AS SHOWN	DATE MAY 13 2011
WORKING DRAWING		
© COPYRIGHT RESERVED 版權所有		

Plot File: B:\USERS\SDATES

\$FILE\$

Leighton JV

Contract No. HY/2011/08
Central-Wan Chai Bypass – Tunnel Buildings, Systems and Fittings,
and Works Associated with Tunnel Commissioning
Air Quality Management Plan (East Ventilation Building and East Vent Shaft)

**Appendix E Extract from Approved Preliminary Design
Submission on APS - EPS and Approval Letter**

11. Appendix I – Other Submission

Reference is made to Contractors Response PS37.31 (1) (i) a.

The APS design is a systematic application of proven and proprietary equipment and components to fulfil the specific requirements of the project. FILTRONtec undertook such a systematic application design approach based on ISO9001 certified Quality Processes and Procedures to select and apply their in-house technology to meet the requirements at Madrid's Calle M30 and Sydney's M5 East.

* The APS design is made up of an ESP filter for particle separation and a DeNO₂ filter for gas adsorption. The purpose of the plant is to reduce the amount of particles and NO₂ in the tunnel airstream with a separation efficiency >80%.

Particle Filter

The particle filter, based on Electrostatic Precipitation (ESP) technology, has a modular design. FILTRONtec developed the module as a result of extensive initial research and development during a 6-year program funded by the German government using real tunnel air at the Hamburg Elbe Tunnel. This 5m³/s research APS enabled FILTRONtec to refine the shape and configuration of the ESP module and to optimise efficiency for various input high voltage currents to both the ioniser and collector plates. The FILTRONtec ESP module characteristics are summarised in Table 1.

Table 1: ESP Module Characteristics

Module	Module Dimensions	Preferred airflow rate	Average airflow treated at 5m/s
ESP	934mm (wide) x 600mm (high) x 600mm (deep) Average cross section inclusive of racking: 0.59m ²	3 to 7m/s at the ESP face	2.5-3m ³ /s
PI	934mm (wide) x 1200mm (high) x 600mm (deep) Average cross section inclusive of racking: 1.2m ²	3 to 7m/s at the PI face	5-6m ³ /s

Pre-Ioniser (PI) Characteristics

The purpose of the PI is to charge the air borne particles with a negative charge. This is done to increase the percentage of particles exposed to the high voltage. The negative electrons are emitted by the spraying electrodes and attach to the surface of the particles that obtain a negative charge.

Each module is made up of a series of neutral plates and spraying electrodes that are negatively charged to 12kV. The PI largely prevents larger particles shadowing the more numerous smaller particles thus increasing the effectiveness of small particles attracting a negative charge. The PI enhances considerably the separation rate and overall efficiency of particle collection that occurs in the ESP. The PI characteristics are summarised in Table 2.

Table 2: PI Characteristics

Characteristic	Measure
Module dimensions approx. (H x W x D)	1.26m x 0.94m x 0.6m
Voltage	12kV
Material	Stainless steel AISI 316Ti
Weight of module approx.	120 kg

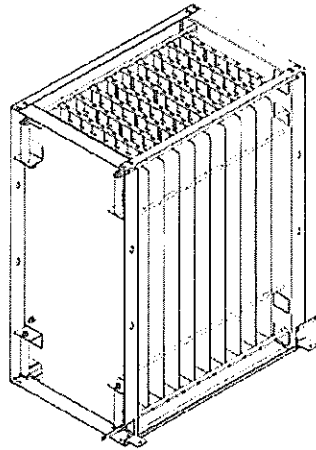

Figure1: PI Module.

Electrostatic Precipitator (ESP)

The main function of the ESP is to ionise particles and then to collect the charged particles on the charged and grounded collector plates.

The ESP modules are made up of parallel stainless plates; the leading half moon shaped plates are live negative discharge ionising plates that carry a charge of 12kV. In order to secure a long service life the discharging point of the half moon electrode plates are used instead of discharging wires. The bulk of the ESP is made up of 87 live and grounded stainless steel plates. The live collector plates are negatively charged to 6kV to form a corona electric field with the grounded parallel plates to ensure almost 100% of particles passing through the ESP are collected. The ESP characteristics are summarised in Table 3.

Table 3: ESP Characteristics

Characteristic	Measure
Module dimensions approx. (H x W x D)	0.63 m x 0.94 m x 0.59 m
Voltage: Ioniser	12 kV
Voltage: Collector	6 kV
Material	Stainless steel AISI 316Ti
Weight of filter module approx.	160 kg

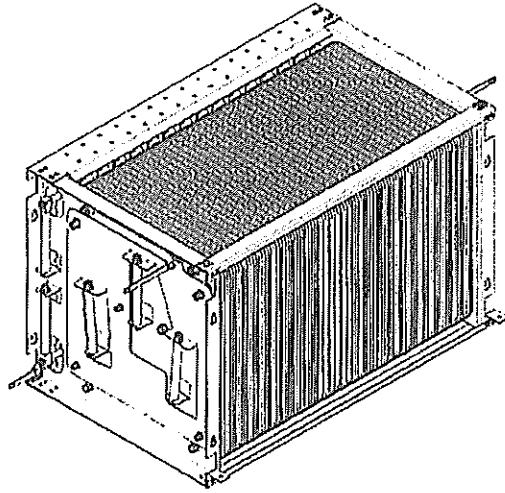

Figure 2: ESP Module

The PI and ESP modules are supported by a SS rack and flat sheeting infill panels between the rack and duct ceiling and walls

ESP Sizing on Previous Contracts

FILTRONtec designed, supplied and installed three APS plants for the Calle M30 and one APS for the M5 East AFP, each sized to suit the specified airflow velocity and plenum duct size as follows in Table4.

Table 4: ESP Sizing

APS	Flow Capacity	Nominal Plenum Size width x height	Plenum Air velocity (Airflow/Plenum Cross Section)	ESP Modules
Calle M30 CT4 (Acciona)	50m ³ /s	Inlet 3.6m x 5m (18m ²)	2.8m/s	9 PI Modules (3 wide x 3 high) 21 ESP Modules (3 wide x 7 high) Total ESP face area 12.4m ² and ESP face velocity of 4.03m/s
Calle M30 CT6 (Acciona)	260m ³ /s	Inlet 10m x 6m (60m ²)	4.33m/s	36 PI (8 x 4 + 4) 89 ESP (7 w x 11 h +12) (52.5m ² – 4.95m/s)
Calle M30 PV5 (FCC)	200m ³ /s	Inlet 12.7m x 5m (63.5m ²)	3.15m/s	77 ESP (7 x 11) ⁽¹⁾ (45.43m ² – 4.4m/s)
M5 East AFP (RTA)	200m ³ /s	Inlet (10m x 5m) (50m ²)	4m/s	38 PI (10 x 2 + 9 x 2) 79 ESP (9 x 8 + 1 x 7) (46.6m ² – 4.29m/s)

Note (1): Contractor FCC elected not to order the APS with PI on PV5 for cost reasons.

Structural Steel Design & Sizing

All supporting racks for PI and ESP modules were designed by certified structural engineer based on international standards for loadings, stress analysis and commonly available section sizes. The rack design for each of the above FILTRONtec APS applications were based on one module per rack opening and sized as 50mm x 50mm x 4 RHS SS standards and 50 x 50 x 5 SS angles.

Hydraulic Piping Design & Sizing

Water was used to clean the ESP on a regular basis. For this reason pipes with spray nozzles were installed on both sides of the ESP. These pipes connect to a manifold with valves and a collecting pipe that connects the APS plenum and the auxiliary equipment room. Pipe sizing is calculated on the basis of water volume and pressure loss following the standard DIN 1988 T3. The volume is dependent on the number of modules per APS. The pressure loss is a function of pipe length, pipe mounting (number of changes of directions), and number and type of fittings (valves, flow restrictors and nozzles).

In principle two types of pipes were used. Standard stainless steel pipes are installed directly at the ESP rack. They are pre-manufactured to length and welded DIN standard flanges (DIN 2631) are fitted for on site connection. Nozzles stubs are also welded ready for screw-in nozzles. The flange connection allows for easy removal in the unlikely event of a module replacement. All other pipes (connection to manifold and collecting pipe to auxiliary room) are press-fitting pipes using the Geberit Mapress system. This

**Contract No. HY/2011/08 – Central Wan Chai Bypass
Tunnel Buildings, Systems and Fitting, and Works Associated with Tunnel**

allows a quick and easy installation on site without welding and guarantees a leakage free operation. All pipes are made from stainless steel (AISI 316) in accordance with the specification.

The sizing of pipe diameters as well as the number, type, and location of flow restrictors is done to assure that the pressure at all nozzles across the corresponding ESP is equal. This is indispensable to assure an equal cleaning of the filter. For example the calculation for WVB-APS-001, shown in drawing FT-HCWB-2211, is shown in Table .

Table 5: Pipe Sizing

Pipe Section	Design Criteria	Sizing
Main feeder (Clear water from auxiliary room to ESP Manifold)	Flow: 4.97 l/s Typical length: various, from 6m to 65m Loss: up to 900 mbar	DN50
ESP manifold	Ball valves Typical length: 6m Loss: 300 mbar	DN50
ESP wash piping	Variable across the ESP face Flow: 4.97...0.71 l/s Length: min 1.5m for every size Loss: 8...15 mbar/m	DN50, 40, 32, 25
Spray piping	Flow 0.18 l/s Length: 1m Loss (incl. nozzles): 0.5 mbar	DN20
Waste Water pipe (sump to dirty water tank)	Flow: 4.45 l/s Length: various, from 15m to 65m Loss: up to 2200 mbar	DN50

Auxiliary Equipment Sizing

FILTRONtec equipment characteristics are summarised in Table .

Table 6: Auxiliary Equipment Characteristics

Element	Characteristic	Remarks
HV Transformers	9kV@4.6kVA ESP collector 18kV@4.6kVA ESP ioniser 18kV@4.6kVA Pre-ioniser	1 set per APS plant Electrical calculation by Rico-Werk
Washdown	3m ³ per 125m ³ /s plant 5m ³ per 250m ³ /s plant	1 Set per APS
Clear water tank size	External tank dimension: W 1.9m x L 1.9m x H 2.5m	Capacity to undertake multiple cycles without refilling
Wash Pumps	Selected Lowara Pumps	Dual cycle redundancy
Manifold piping	50mmDN and 40mmDN	
Nozzles	Bete 1/8 MPL0.57 M7	
Sump Pumps	Selected Lowara Pumps	Dual cycle redundancy
Dirty water tank	External tank dimension: W 1.9m x L 1.9m x H 2.5m	Collect 2 washdown cycles and retain concentrated sludge
Compressor and receiver	1300lt/min capacity Receiver: 5000lt	One per APS plant
Recycling Plant	Ultrafiltration plant, 2000lt/h, 6 bar	One per APS

Other Component Design

- *Roughing Filter*

All of the supplied APS plant included a Roughing Filter sized as 50mm x 50mm steel mesh on Unistrut frames 1m x 1.8m grid incorporating an access door.

- *Infill Walls*

Infill walls between the ESP frame and APS plenum walls and ceiling prevent air bypassing the filters. Flat SS sheeting supported on SS RHS/Angle frames

- *Turning Vanes*

Turning vanes were not required on the three plants built in Madrid, as the airflow was a direct bypass parallel to the road tunnel.

On the M5 East the building design provided 180° bend immediately before the ESP filter. FILTRONtec conducted a CFD analysis and designed the turning vanes to accommodate the main door to the plant. This access door restricted the turning vane design to an effective 90° bend causing some issues with even airflow coming onto the particle filter. The turning vanes were designed as 1.2mm galvanised steel sheeting riveted to galvanised steel 50 x 50 RHS sections configured as required by CFD analysis. Figure 3; below indicated the position and configuration of the Turning Vanes located at the 180° bend in the Air Inlet.

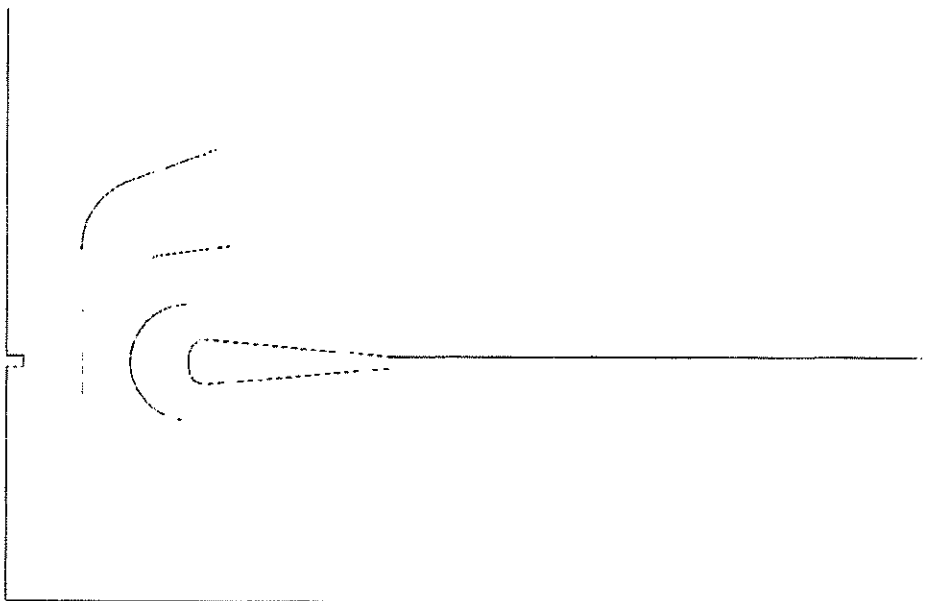

Figure 3: Location and positioning of the inlet turning vanes determined by CFD

- *Air Monitoring*

In all of the APS plants built by FILTRONtec and Camfil the authorities have specified the sensors to be used to measure the plant efficiency.

In Madrid Grimm particle counting devices were specified and worked well when correctly calibrated for each plant.

In Sydney the Air Monitoring System measured the gas and dust concentrations with respect to Carbon Monoxide (CO), Oxides of Nitrogen (NO, NO₂ and NO_x), Ozone (O₃), Visibility (bscat) and Particles

**Contract No. HY/2011/08 – Central Wan Chai Bypass
Tunnel Buildings, Systems and Fitting, and Works Associated with Tunnel**

(PM₁₀ and PM_{2.5}).

The Air Monitoring System within the AFP comprises the following units:

- Unit 1 located in Air Inlet to AFP upstream of the Filter System
- Unit 2 located between ESP and Denitrification plant
- Unit 3 located downstream of the Denitrification plant
- Unit 4 located downstream of the Main Ventilation Fans
- There are four Flow Meters
 - One near Unit 1 on the air inlet side
 - Two, either side of the DeNO_x Pressure Wall, positioned to provide both a calculated airflow around and through the DeNO_x, when the DeNO_x fans are operating.
 - One between Attenuator 2 and the Outlet Damper.

The Air Monitoring System located in the M5East Westbound Tunnel is made up of the following units:

- Anemometer (flow meter) as well as visibility and CO monitors 50 metres East of the Inlet;
- Anemometer (flow meter) and temperature sensor between the Inlet and Outlet; and
- Anemometer (flow meter) as well as visibility and CO monitors 50 metres West of the Outlet

The specific equipment types are briefly described in Table 7 below:

Table 7: M5East Air Monitoring Unit Characteristics

Asset		Equipment Make/Model	Measure
Unit	Location		
Unit 1	Air Inlet to Plant	Thermofisher Gas Analysers: <ul style="list-style-type: none"> • Thermo Scientific Model 42i • Thermo Scientific 48i • Thermo Scientific 49i 	NO, NO ₂ and NO _x CO O ₃
		<ul style="list-style-type: none"> • TEOM 1405-DF- Thermofisher Scientific 	Particulate (PM ₁₀ and PM _{2.5})
		<ul style="list-style-type: none"> • Ecotech Aurora-1000 Single Wavelength Integrating Nephelometer 	Visibility
		<ul style="list-style-type: none"> • Meteorological sensors 	Relative Humidity, Temperature and Pressure
		<ul style="list-style-type: none"> • ENVIDAS Data logger and Software 	Correcting and standardizing outputs.

		ENVIRONICS Gas Calibration System <ul style="list-style-type: none"> Series 7000 Zero Air Generator Environics Model 6100 Multi-gas Calibrator Calibration Gas Bottles 	Calibration of Gas Analyser NATA Certified
Unit 2	Downstream of ESP	Thermofisher Gas Analyzers: <ul style="list-style-type: none"> Thermo Scientific Model 42i Thermo Scientific 48i 	NO, NO ₂ and NO _x O ₃
		<ul style="list-style-type: none"> TEOM 1405-DF- Thermofisher Scientific 	Particulate (PM ₁₀ and PM _{2.5})
		<ul style="list-style-type: none"> ENVIDAS Data logger and Software 	Correcting and standardizing outputs.
		ENVIRONICS Gas Calibration System <ul style="list-style-type: none"> Series 7000 Zero Air Generator Environics Model 6100 Multi-gas Calibrator Calibration Gas Bottles 	Calibration of Gas Analyser NATA Certified
Unit 3	Downstream of DeNOx	Thermofisher Gas Analyzers: <ul style="list-style-type: none"> Thermo Scientific Model 42i Thermo Scientific 48i 	NO, NO ₂ and NO _x O ₃
		<ul style="list-style-type: none"> ENVIDAS Data logger and Software 	Correcting and standardizing outputs.
		ENVIRONICS Gas Calibration System <ul style="list-style-type: none"> Series 7000 Zero Air Generator Environics Model 6100 Multi-gas Calibrator Calibration Gas Bottles 	Calibration of Gas Analyser NATA Certified

Unit 4	Downstream of Plant	ThermoFisher Gas Analyzers:	NO, NO ₂ and NO _x CO O ₃
		<ul style="list-style-type: none"> Thermo Scientific Model 42i Thermo Scientific 48i Thermo Scientific 49i 	
		<ul style="list-style-type: none"> TEOM 1405-DF- ThermoFisher Scientific 	Particulate (PM ₁₀ and PM _{2.5})
		<ul style="list-style-type: none"> Ecotech Aurora-1000 Single Wavelength Integrating Nephelometer 	Visibility
		<ul style="list-style-type: none"> ENVIDAS Data logger and Software 	Correcting and standardizing outputs
		ENVIRONICS Gas Calibration Systems	Calibration of Gas Analyser
		<ul style="list-style-type: none"> Series 7000 Zero Air Generator Environics Model 6100 Multi-gas Calibrator Calibration Gas Bottles 	NATA Certified
Flow Meters		<ul style="list-style-type: none"> DURAG Ultrasonic Flow Monitor 	Measures air velocity across the air stream and calculates air flow (m ³ /s)

DeNO₂ Filter

FILTRONtec designed, supplied and installed a 50m³/s DeNO₂ filter as part of the M5 East AFP as described in Figure 4 below:

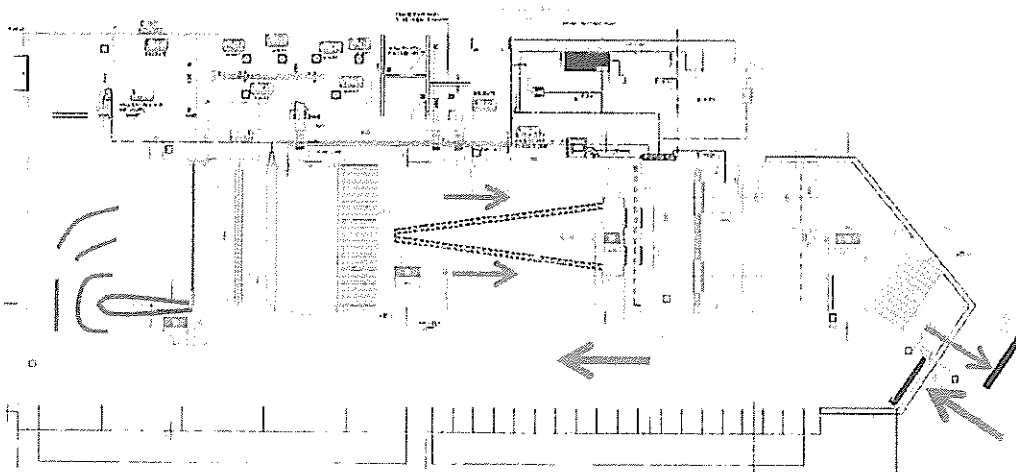

Figure 4: M5East Air Filtration Plant

Sizing the DeNO₂ Filter

The Activated Carbon was made from coconut husks that have undergone a steam activation process. Activated carbon is a non-graphite form of carbon, which works by the process of adsorption. Adsorption is when one material adheres to the surface of another material by means of physical and/or chemical attraction between the materials.

Table 8 provides the characteristics of the Activated Carbon.

Table 8: Activated Carbon Characteristics

Characteristic	Value
pH Value	6.6 – 7.7
Methylene Value adsorption	190 – 350mgm/gm.
Adsorption capacity as % by mass	45% minimum
Moisture	5% maximum
Ash	5% maximum
Hardness	90

The design of the denitrification plant was based on the properties and performance characteristics provided by the activated carbon manufacturer; Carbon Activated Corporation that stated: Under air evasion of hydrocarbons emitting from atmospheric air the removal of nitrogen monoxide, nitrogen dioxide, ozone, benzene and hydrocarbons percentages below table 9:

Table 9: Activated Carbon Performance Characteristics

NO	: 40% max
NO2	: 98%
O3	: 99%
Hydrocarbons/Benzene	: 99%

Residency time for gases to be in contact with the activated carbon was assumed as 0.7 seconds.

The carbon walls were designed to be 500mm thick with an airflow velocity of 0.5m/s to provide a residency time >0.7 seconds. The pressure drop was assessed as 500Pa and the dedicated DeNO_x fans were sized to draw air through the sealed carbon array. The design is summarised in Table 10.

Table 10: DeNO₂ Array Sizing

APS	Flow Capacity	DeNO ₂ Modules
M5East	50m ³ /s	Vee Formation 9m Long x 5m High Total DeNO ₂ face area 120m ² and face velocity of 0.45m/s

The Activated Carbon is contained in stainless steel boxes 515mm deep x 405mm wide x 300mm high with two opposing sides made from stainless steel mesh while the base and the other two sides are flat SS as shown in Figure 4 below.

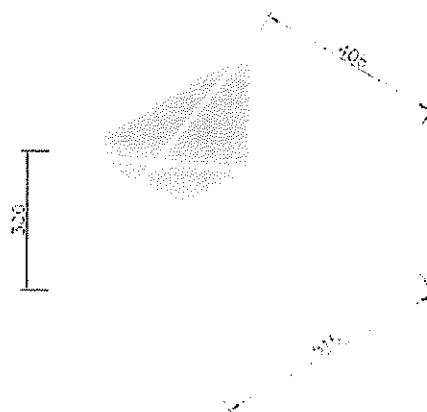

Figure 4: Activated Carbon Box

**Contract No. HY/2011/08 – Central Wan Chai Bypass
Tunnel Buildings, Systems and Fitting, and Works Associated with Tunnel**

There are a total of 1008 boxes, made up of 2 rows x 4 boxes per node. There are 7 rows x 9 columns of nodes on both sides of the V containing approximately 30,000kg of Activated Carbon all supported in a V-rack.

A stainless steel lid is installed to the top of each section of 8 boxes to prevent carbon from being drawn out and lost due to the airflow in and around the DeNOx array.

The DeNOx boxes are sealed using stainless steel strips, horizontal and vertical with neoprene seals, all bolted in place.

4. Factors Affecting Efficiencies

It has been demonstrated in the above application examples that FILTRONtec has a deep understanding of the specification and application of filtration technology. The CWB Particular Specification reflects the design and development resulting from research and application.

In all previous applications FILTRONtec has applied its technology generally in accordance with that proposed by the CWB PS.

However there have been some significant lessons learned from the applications to date and further laboratory testing conducted by FILTRONtec on their ESP modules and Camfil on activated carbon. These are summarised in Table 11 below:

Table 11: Lessons Learned from previous Projects

Issue	Lessons Learned
Spatial Requirements	Engage with designers early in the project development stage in an endeavour to influence the airflow design path to ensure even airflow to the filters. Eg. In Sydney there was the need to install turning vanes to bring the air through 180 degrees but a large access door to the plant restricted the vanes to a less than satisfactory 90° effort
Airflow analysis	Even airflow onto the particle and gas filters ensures greater performance. Conduct preliminary CFD and detailed CFD analysis to provide optimised airflow onto the filter. Avoid 180° bends prior to the filters
Air Monitoring	Avoid prescribed instruments that work well in open atmospheric conditions but fail in the adverse concentrated APS applications. Encourage owners to specify performance rather than specific equipment. Provide sensors that have high levels of accuracy to achieve meaningful separation rates. Avoid standard tunnel monitoring sensors due to low accuracy. Choose sensors that require low maintenance and house them within climate controlled cabinets, Eg. In Sydney the specified particle measurement devices (TEOM 1405-DF) required cleaning every second day to achieve some effective measures.
DeNO ₂ Filters	Use of individual boxes to contain carbon led to settlement issues and airflow bypass effecting the efficiency of the carbon filter. Design an efficient activated carbon containment structure to avoid air bypass.

	<p>Choose activated carbon that is mechanically strong and adsorbs NO₂ in the presence of hydrocarbons (M5 coconut based carbon is both brittle and susceptible to poor performance in the presence of hydrocarbons).</p> <p>Use rigorous selection techniques to choose carbons that perform under similar conditions.</p>
Carbon Filling	<p>Manhandling carbon on site creates hazardous safety issues.</p> <p>Use mechanical loading devices to install carbon.</p>
Water Ingress to DeNO ₂ Filter	<p>During washdown and particularly during the high-pressure air-drying of the ESP filter moisture can travel downstream to impact the AMS and DeNO₂ filter. In Sydney this had some impact on the ventilation silencers, which were placed between the ESP and DeNO₂.</p> <p>Installation of a roller shutter after the ESP will limit such water transfer.</p>
Constructability	<p>Welding ESP racks on site was found to be time consuming and subjected to work restrictions under safety hazard analysis.</p> <p>Pre-fabricate ladder sections and use bolted connections for safer and speedier site installation.</p>
ESP Filters	<p>Conduct further laboratory tests on the ESP filters to optimise the ionising and collector voltage.</p> <p>The filters proposed for CWB have undergone extensive further research and the plate configuration and applied voltages have been altered to provide enhanced performances</p>

All of the above lessons learned are covered within the PS37 and FILTRONtec complies with the requirements as detailed in Contractor Response to PS37.31.i c.

1 ESP Laboratory Performance Tests

FILTRONtec continues an active research and development program for the continuous improvement of the particle separation using ESP technology. In 2013 FILTRONtec finalised a series of tests in conformity with the specified design criteria detailed in PS37 2 (1) on the module planned for use on CWB varying airflow velocity against a number of application set points for energising the ioniser and collector components of the ESP modules. The excellent results are highlighted in the following test report charts.

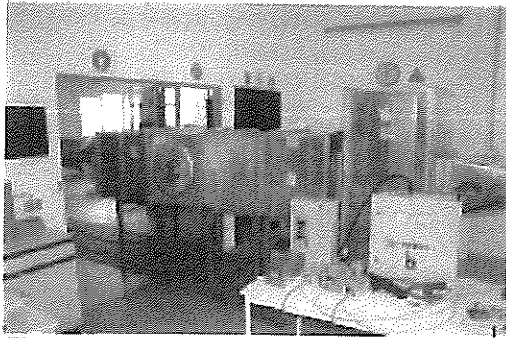
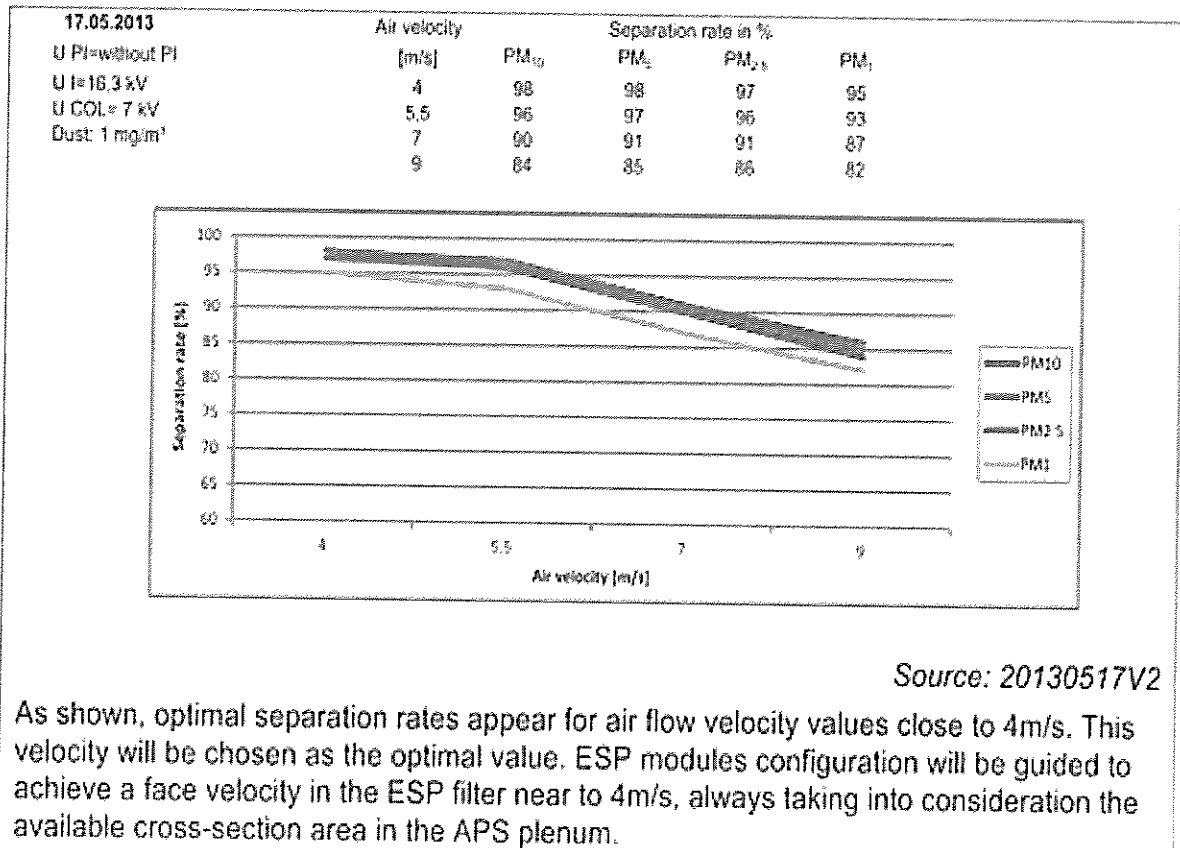

Figure 1: FILTRONtec Testing Laboratory



Maximum filter size to be tested	Up to 600 x 600 x 600 mm
Temperature range	5 to 50 deg C
Relative humidity range	20 to 90% RH
Maximum flow rate	4000 m ³ /h
Challenge gases	Including Nitrogen dioxide, hydrogen sulphide, sulphur dioxide, ammonia, ozone
Challenge vapours	Virtually any organic compound that can be volatilised

This laboratory has been extensively used to advance Camfil's knowledge of nitrogen dioxide filtration. In particular, using ambient realistic concentrations (high parts per billion – low parts per million), Camfil have studied:

- i) The efficiency and adsorptive capacity of a wide range of adsorbents
- ii) The effect of temperature
- iii) The effect of relative humidity
- iv) The effect of a co-challenge of ozone (to replicate possible emission from ESP)
- v) The effect of the presence of VOCs (to replicate vehicle exhaust emissions in a tunnel environment)

Using data collected over 50 years from real world installations and from nearly 20 years of laboratory work and using accepted scientific adsorption equations, Camfil have developed a very powerful software to simulate efficiency and lifetime of molecular filtration installation. This includes nitrogen dioxide applications.

Camfil are self-sufficient in terms of evaluating the performance of nitrogen dioxide filtration solutions. We have not previously engaged the services of external providers.

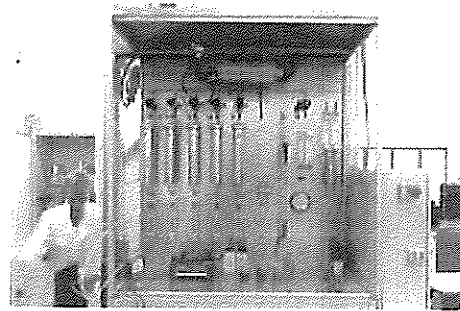
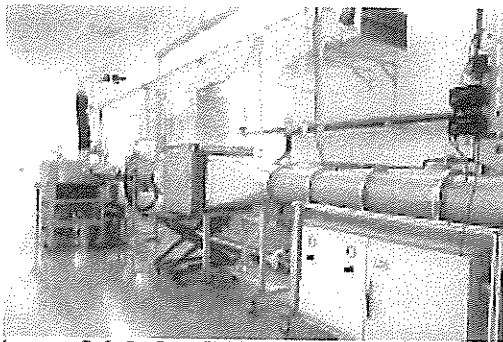

Figures 2 & 3 Camfil Molecular Filtration Test Laboratory

2.1 Post Installation - Lifetime Determination of Carbon Media

The Camfil molecular filtration laboratory offers a unique method to very accurately monitor the condition of the carbon during use and predict the end of life or failure point of the carbon. Samples will be withdrawn from the installation at 6 month intervals (proprietary method). The samples will be subjected to exactly the same nitrogen dioxide challenge tests as the new material (during FAT). Tracking the deterioration in the performance of the carbon with time provides an effective predictive tool for anticipating end of filter life.

To be provided at FAT - initial efficiency curve only

2.2 Carbon Ignition Tests

These will not be undertaken until the FAT.